

# Infiltrator IM- and CM-Series Tank Buoyancy Control Guidance



## Before you Begin

This guidance document presents a method for assessing buoyancy control needs for Infiltrator Water Technologies (Infiltrator) IM- and CM-Series tanks. Tank buoyancy control measures must be implemented according to state and/or local regulations and approvals, which may supersede these guidelines. If unsure of the requirements for a particular site, contact the state or local health department or permitting authority.

If tank buoyancy control measures are implemented, refer to Infiltrator IM- and CM-Series Tank General Installation Instructions and Riser Connection Guidance documents, as applicable, for completing the installation. This guidance document is not a tank installation instruction document.

## How to Use this Document

- Using Step 1, Table 1, and Figures 1 and 2, verify that the level of subsurface water is below the height of the outlet pipe saddle and determine if buoyancy control is required. See page 2 notes on terminology.
- Use the appropriate row in Step 2, Table 2 to determine the minimum buoyancy control methods for the site conditions.
- Once the preferred buoyancy control method is selected, follow the implementation procedures provided in Step 3.

## Step 1 – Determine Need for Buoyancy Control

Required information: (1) maximum height of subsurface water above the tank bottom; and (2) the depth of soil cover above the tank top. Tank buoyancy control may be required if:

- the level of subsurface water outside the tank has the potential to rise 30 inches (750 mm) or more above the bottom of the tank; and
- less than 12 inches (300 mm) of soil cover is to be placed as backfill over the tank top.

**NO BUOYANCY CONTROL IS REQUIRED IF THERE ARE AT LEAST 12 INCHES (300 MM) OF SOIL COVER ABOVE THE TANK TOP.**

## Table 1 Instructions

- In the left-hand column of Table 1, locate the row corresponding to the height of the subsurface water elevation outside the tank and above the tank bottom (Parameter I) for the site conditions. See Figure 2.
- Follow that row to the right until reaching the column corresponding to the depth of soil cover above the tank top (Parameter II). See Figure 2.
- If the tank model is listed in that cell, then buoyancy control is required, proceed to Step 2. If the tank model is not listed in that cell, then no buoyancy control is required.
- IM- and CM-Series tanks shall not be installed where the subsurface water level outside the tank exceeds the height of the outlet pipe saddle. See Figure 1.

**Table 1: Infiltrator Tank Models<sup>1</sup> and Conditions Requiring Buoyancy Control**

Parameter I: Subsurface water height above tank bottom		Parameter II: Soil cover depth above tank top <sup>2</sup>	
		A	B
		6 in (150 mm) up to 12 in (300 mm)	12 in (300 mm) or greater
1	Above outlet pipe saddle <sup>3</sup> (greater than 43" [1,075 mm])	Do not install tank	Do not install tank
2	36" (900 mm) to 43" (1,075 mm) (to outlet pipe saddle)	All models	Not Required
3	30" (750 mm) to 36" (900 mm)	IM-1530	Not Required
4	Less than 30" (750 mm)	Not Required	Not Required

### Notes:

- Infiltrator tank models include: IM-540, IM-1060, CM-1060, and IM-1530.
- Minimum 6 inches (150 mm) soil cover backfill is required.
- IM- and CM-Series tanks shall not be installed where the subsurface water level outside the tank exceeds the height of the outlet pipe saddle. See Figure 1.
- For Indiana installations, if the depth of uninterrupted saturated soil conditions cannot be determined from the site soil evaluation report or other site-related data and other information indicates the possible presence of a perched ground water table, no buoyancy controls are required. See page 2 note on terminology.

**Figure 1: Limitations When Subsurface Water is Present Above Tank Bottom**

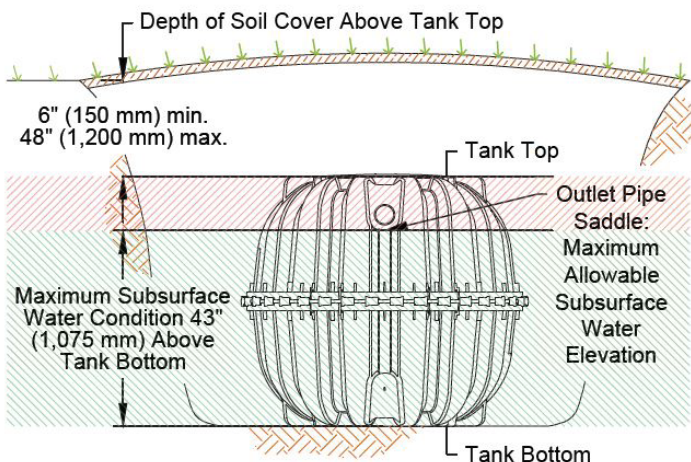

**Figure 2: Buoyancy Control Parameters for Table 1**

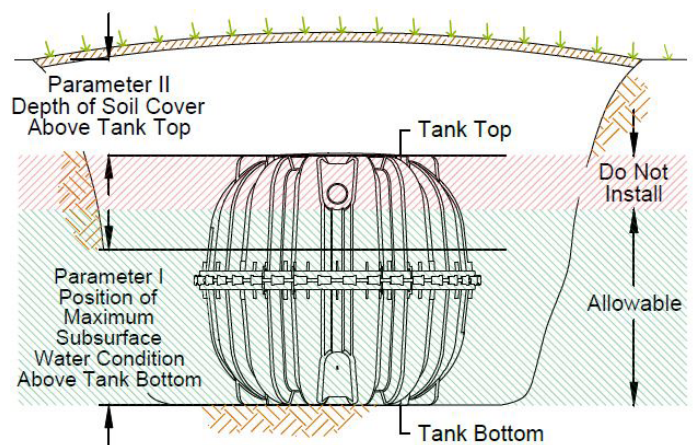

### Installation Terminology Notes:

1. “Subsurface water” refers to a water-saturated zone of soil. Do not install if subsurface water is continuous from the tank bottom elevation to any point above the outlet pipe saddle elevation.
2. “Uninterrupted saturated soil” refers to water-saturated soil with no gaps in the saturated condition. An example of a gap in the saturated condition is a perched water table, when two water-saturated soil zones are interrupted by an unsaturated soil zone. Do not install if uninterrupted saturated soil is present from the tank bottom elevation to any point above the outlet pipe saddle elevation.
3. A perched water table is allowable above the outlet pipe saddle elevation only if unsaturated soil is present between the perched water table zone and tank bottom elevation.

## Step 2 – Determine Buoyancy Control Method

Step 2 is used if the Step 1 analysis shows that buoyancy control is required for the tank model and installation conditions. The site-specific maximum height of subsurface water outside of the tank and above the tank bottom and the depth of soil cover above the tank top must be known to complete Step 2.

### Table 2 Instructions

For the appropriate tank model, select the desired buoyancy control method under each method description column. Refer to Step 3 – Implementation and Supplemental Technical Guidance sections of this document for additional information on the buoyancy control methods shown in Table 2.

**Table 2: Buoyancy Control Method Selection**

Tank Model	Parameter 1: Position of subsurface water above tank bottom	Parameter 2: Soil cover depth above tank top	Buoyancy Control Methods <sup>1</sup>									Minimum supplemental downward force required <sup>4</sup> (total, both tank sides)		
			Wood Beam Anchor Ballast Options (min. length/side)			Concrete Beam Anchor Ballast Options (min. length/side)			Precast concrete plates (min. no./side)	Helical anchors <sup>2</sup> (min. no./side)	Anchor-lock system <sup>2</sup> (min. no./side)		Concrete collar (min. width x min. height)	
			1 6"x6" beam	2 6"x6" beam with cross-	3 6"x6" beam side-by-side	1 6" wide	2 8" wide	3 12" wide						
IM-540	36 in (900 mm) to outlet pipe saddle <sup>3</sup>	6 in (150 mm) to 12 in (300 mm)	3.8 ft (1.2 m)	3.8 ft (1.2 m)	3.8 ft (1.2 m)	3.8 ft (1.2 m)	3.8 ft (1.2 m)	3.8 ft (1.2 m)	3.8 ft (1.2 m)	2	2	2	6 in (150 mm) x 9 in (225 mm)	1,000 lbs (450 kg)
IM-1060	36 in (900 mm) to outlet pipe saddle <sup>3</sup>	6 in (150 mm) to 12 in (300 mm)	7.5 ft (2.3 m)	6.0 ft (1.8 m)	5.5 ft (1.7 m)	7.5 ft (2.3 m)	6.5 ft (2.0 m)	5.0 ft (1.5 m)		2	2	2	6 in (150 mm) x 9 in (225 mm)	3,550 lbs (1,620 kg)
CM-1060	36 in (900 mm) to outlet pipe saddle <sup>3</sup>	6 in (150 mm) to 12 in (300 mm)	4.8 ft (1.5 m)	4.8 ft (1.5 m)	4.8 ft (1.5 m)	6.3 ft (1.9 m)	5.5 ft (1.7 m)	4.8 ft (1.5 m)		2	2	2	6 in (150 mm) x 9 in (225 mm)	2,200 lbs (1,000 kg)
IM-1530	30 in (750 mm) to outlet pipe saddle <sup>3</sup>	6 in (150 mm) to 12 in (300 mm)	Use alternate method	10.0 ft (3.0 m)	9.5 ft (2.9 m)	Use alternate method	Use alternate method	Use alternate method		2	2	2	9 in (225 mm) x 9 in (225 mm)	6,200 lbs (2,820 kg)

### Notes:

1. See method-specific technical specifications and installation instructions below.
2. See manufacturer-specific information below.
3. IM- and CM-Series outlet pipe saddle height is 43 inches (1,075 mm) above tank bottom (see Figure 1).
4. Supplemental downward force is provided for custom-designed anchor ballast systems. See discussion below.

## Step 3 – Implementation

Effective buoyancy control requires careful preparation, proper excavation, precise placement, secure strapping and proper backfilling, as described and illustrated in Step 3 below and the Infiltrator IM- and CM-Series Tank Installation Instructions. Step 3 includes specifications and system installation guidance for five buoyancy control system categories.

- 3-1: Beam Anchor Ballast
- 3-2: Precast Concrete Plate Anchor Ballast
- 3-3: Helical Anchors and Anchor-Lock Assemblies
- 3-4: Concrete Collar Anchor Ballast
- 3-5: Custom-Designed Buoyancy Controls

Following Step 3, supplemental technical guidance is provided for use with these buoyancy control methods. See the Supplemental Technical Guidance section for strap information as well. Straps meeting the appropriate are available from IWT (TANK-BCS-KIT). This guidance document is not a tank installation instruction document. Refer to the Infiltrator IM- and CM-Series Tank Installation Instructions for complete information on tank installation requirements.

### Step 3-1: Beam Anchor Ballast

The beam anchor ballast options shown in Table 2 include the installation of wood or concrete beams adjacent to the tank, connected with two straps positioned across the top of the tank. The beam anchor ballast option allows the installer to select either beam construction material. The beam options resist tank buoyant forces using the weight of the soil column over the beam anchor ballast to counteract uplift. Therefore, it is critical that the widest dimension of the beam be placed horizontally on the base of the tank excavation, running parallel with the length of the tank. Beam construction materials shall meet the following specifications:

- Pressure-treated lumber shall be American Wood Protection Association (AWPA) Use Category UC4B, UC4C, UC5B, or UC5C.
- Concrete parking bumpers (also referred to as wheel stops) shall be steel-reinforced concrete with dimensions of 6-, 8-, or 12-inches wide by 6 inches high (150 mm, 200 mm, or 300 mm wide x 150 mm high).
- Fasteners shall be hot-dipped galvanized steel or stainless steel.

**⚠ WARNING: Infiltrator does not recommend the use of beams fabricated using thermoplastics, including, but not limited to, chambers, pipe, decking, and parking bumpers.**

## Wood Beams

The wood beam anchor ballast can be configured three ways, depending on material and space availability:

- Wood Beam Option 1: Pressure-treated 6" x 6" – This option includes a single 6" x 6" beam connected to straps on each side of the tank (Figure 3).

**Figure 3:** Wood Beam Option 1

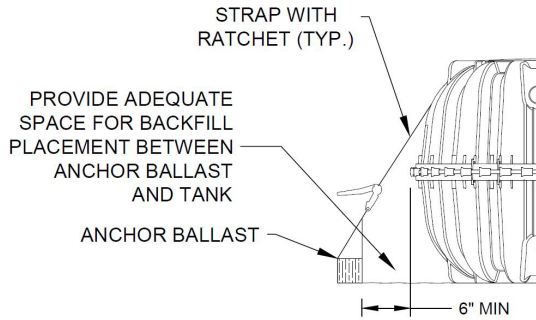

- Wood Beam Option 2: Pressure-treated 6" x 6" with cross-members – This option includes a single 6" x 6" beam on each side of the tank equipped with a series of pressure-treated wood cross-members to increase the surface area of the beam, connected to straps (Figure 4). Cross-members shall be 2" x 8" x 18" connected to the beam with four screws per member and distributed uniformly along the long axis of the beam. Cross member placement must not interfere with the strap locations.

**Figure 4:** Wood Beam Option 2

- Wood Beam Option 3: Pressure-treated 6" x 6" members placed side-

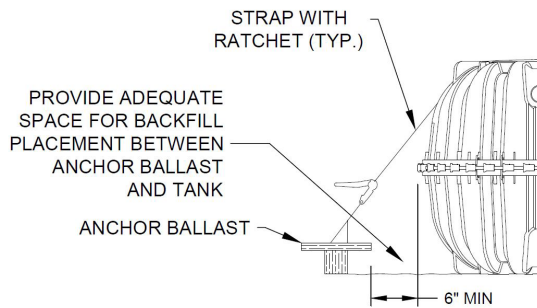

by-side – This option includes two 6"x6" beams placed side by side and connected to looped straps on each side of the tank (Figure 5). The beams shall be connected using two 2" x 6" members screwed to the top and bottom of the side-by-side beams in two locations near the ends of the beams. Fasteners shall be 3.5-in screws with washers.

**Figure 5:** Wood Beam Option 3

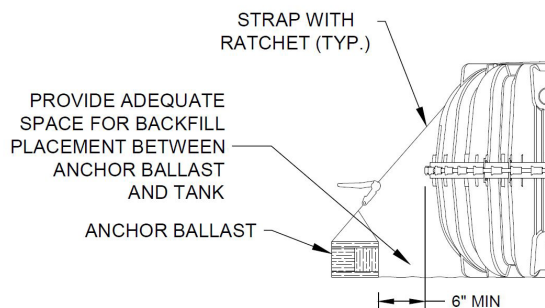

## Concrete Beams

The concrete beam can be configured three ways, depending on material and space availability, using parking bumpers (also referred to as wheel stops). This option includes a single concrete beam connected to straps on each side of the tank (Figures 6 and 7). Three concrete beam anchor ballast options are available, depending upon the parking bumper width as follows:

- Option 1: 6-in-wide precast concrete parking bumper
- Option 2: 8-in-wide precast concrete parking bumper
- Option 3: 12-in-wide precast concrete parking bumper

Note that the Concrete Beam Option is not recommended for use with the IM-1530 tank due to limitations in availability of parking bumpers that would be long enough to provide adequate resisting force. Use an alternative buoyancy control method for the IM-1530.

**Figure 6:** Concrete Beam Parking Bumpers

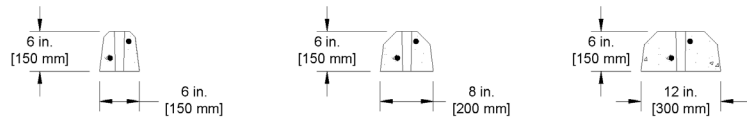

**Figure 7:** Concrete Beam

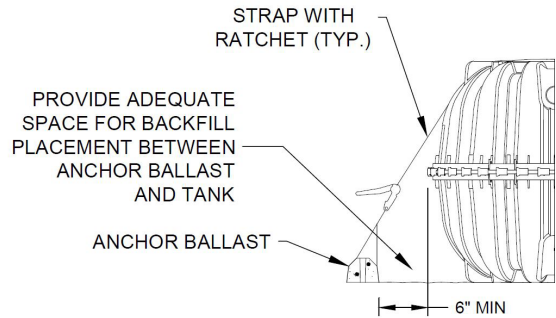
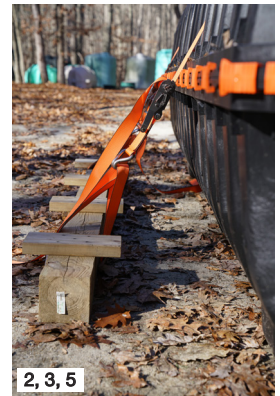

Table 2 provides the minimum length of beam required for the tank model and installation conditions. A minimum 1.5 factor of safety has been applied to determine the minimum required beam length.

Wood and concrete beam installation should be as described below. See Ratchet Strap Material Specifications section below for additional information.

1. Determine the minimum beam length from Table 2.
2. Place beams on the excavation bottom, such that the beam and tank bottoms are at the same elevation. The beam must be oriented with the widest dimension placed horizontally.
3. Position beams parallel to the long axis of the tank.
4. Position beams to be centered between strap locations and extend at least 6 in beyond the strap locations.
5. Position the beam a minimum of 6 in (150 mm) from the outermost footprint of the tank to allow connection of the strap system and placement and compaction of soil backfill below the tank haunches.

**⚠ WARNING: Never place any portion of the anchor ballasts beneath the outermost footprint of the tank, including beneath the haunches.**



Position beam and tank.



Position strap on beam.

**⚠ WARNING: Do Not Use Cable Tie-Downs: The use of cables to connect anchor ballasts in lieu of strapping is prohibited. Cables concentrate the load exerted by the buoyancy control system within a small area on the tank surface, resulting in the potential to damage the tank.**

6. Position the 14-ft-long (4.3 m) strap across the top of the tank at the locations embossed for strap placement (Figure 10).
7. At each beam connection point, wrap the 5-ft-long (1.5 m) looped-end strap to the beam at points aligning with the straps placed across the top of the tank. If the beam includes cross-members, position to prevent interference between looped-end straps and cross-members.
8. Connect the hooked end of the 14-ft-long (4.3 m) strap to the two looped ends of the 5-ft-long (1.5 m) looped-end strap.
9. Connect the non-hooked end of the 14-ft-long (4.3 m) strap to the ratchet.
10. Connect the hooked end of the ratchet strap to the 5-ft-long (1.5 m) looped-end straps, such that the ratchet is positioned below the mid-seam elevation of the tank. Do not allow the ratchet to be in contact with the tank.



11. Remove slack in the straps through a combination of beam positioning and the ratchet, such that the ratchet is positioned below the mid-seam elevation of the tank and not contacting the tank. Maintain the minimum 6-in (150 mm) spacing between the edge of tank and beam.
12. Place and compact backfill beneath the tank haunches and around and above the beams to an elevation 6 inches (150 mm) above the top of the beams. Place and compact backfill as described in the Infiltrator IM- and CM-Series Tank Installation Instructions.
13. With the anchor ballasts stabilized by 6 inches (150 mm) of compacted backfill, tension the strap to eliminate all slack using the ratchet. The tension should make the strap tight, without displacing the beams or damaging the tank.
14. Do not over tighten the straps.
15. Complete backfilling the tank as described in the Infiltrator IM- and CM-Series Tank Installation Instructions.

### Step 3-2: Precast Concrete Plate Anchor Ballast

The precast concrete plate anchor ballast option shown in Table 2 includes the installation of four individual concrete anchor ballasts, connected with straps positioned across the top of the tank. Historically, precast concrete plate anchors have been spare concrete septic tank lids repurposed as anchor ballasts, but they can be fabricated specifically as anchor ballasts as well. The precast concrete plate anchor ballast option allows the installer to select plate size and shape, provided that each plate provides a minimum 4 ft<sup>2</sup> (0.37 m<sup>2</sup>) of horizontal area and minimum 3-in thickness (75 mm). The precast concrete plate anchor ballast options resist tank buoyancy forces using the weight of the soil column over the plate anchor ballast to counteract uplift. Therefore, it is critical that the widest dimension of the plate anchor ballast be placed horizontally on the base of the tank excavation.

Plate construction material shall be precast concrete having a minimum 3,500 psi (24.1 MPa) compressive strength at 28 days and minimum 6% air entrainment. Connectors protruding from the anchor plate and used for strap connection shall be steel reinforcing bar, galvanized steel, or stainless steel capable of supporting a 2,500-lb (1,134 kg) tensile force. Do not use plastic connectors.

**⚠ WARNING: Infiltrator does not recommend the use of plate anchor ballasts fabricated using materials other than concrete.**

The precast concrete plate anchor ballast can be configured using a square, rectangular, or circular shape. For rectangular-shaped anchor ballasts, the long axis of the plate shall be placed parallel with the long axis of the tank. Precast concrete plate anchor ballast sizing and configuration options are shown in Table 3 and Figure 8.

**Table 3: Precast Concrete Plate Anchor Ballast**

Precast concrete plate anchor ballast shape	Minimum horizontal dimensions (minimum 3-in (75 mm) thickness)
Square	2 ft x 2 ft (0.61 m x 0.61 m)
Rectangular	Maintain a 1 ft (0.31 m) minimum width, with length to provide a minimum 4 ft <sup>2</sup> (0.37 m <sup>2</sup> ) horizontal plate area per anchor ballast
Circular	2.3 ft diameter (0.70 m diameter)

As shown in Table 2 and Figure 8, four precast concrete plate anchor ballasts are required for all tank models. The minimum horizontal plate area specifications are the same for all tank models. A minimum 1.5 factor of safety has been applied to determine the minimum horizontal plate area.

**Figure 8: Precast Concrete Plate Anchor Ballast Options**

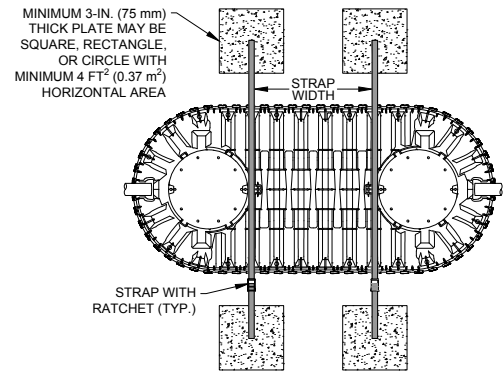

Precast concrete plate anchor ballast installation should be as described below. See Ratchet Strap Material Specifications section below for additional information.

1. Use 4 precast concrete plate anchor ballasts per installed tank.
2. Place anchor ballasts on the excavation bottom, such that the anchor ballast and tank bottoms are at the same elevation. The precast concrete plate anchor ballast must be oriented with the widest dimension placed horizontally.
3. Position anchor ballasts to align with the locations on the tank embossed for strap placement (Figure 10).
4. Position the anchor ballasts a minimum of 6 in (150 mm) from the outermost footprint of the tank to allow connection of the strap system and placement and compaction of soil backfill below the tank haunches.



**⚠ WARNING: Never place any portion of the anchor ballasts beneath the outermost footprint of the tank, including beneath the haunches.**

**⚠ WARNING: Do Not Use Cable Tie-Downs: The use of cables to connect anchor ballasts in lieu of strapping is prohibited. Cables concentrate the load exerted by the buoyancy control system within a small area on the tank surface, resulting in the potential to damage the tank. Cable may damage the tank.**

5. Position the 14-ft-long (4.3 m) straps across the top of the tank at the locations embossed for strap placement (Figure 10).  
6. Connect the hooked end of the 14-ft-long (4.3 m) strap to the concrete anchor ballast hardware. Looped-end straps are not required to connect to the anchor ballast hardware.



5, 8  
Position straps on tank.

7. Connect the non-hooked end of the 14-ft-long (4.3 m) strap to the ratchet.  
8. Connect the hooked end of the ratchet strap to the concrete anchor ballast hardware. Looped-end straps are not required to connect to the anchor ballast hardware.



8  
Connect strap to plate.

9. Position the ratchet below the mid-seam elevation of the tank. Do not allow the ratchet to be in contact with the tank.  
10. Remove slack in the straps through a combination of anchor ballast positioning and the ratchet.



8, 9, 10  
Remove strap slack.

11. Place and compact backfill beneath the tank haunches and around and above the anchor ballasts to a height of 6 in (150 mm) above to top of the anchor ballast. Place and compact backfill as described in the Infiltrator IM- and CM-Series Tank Installation Instructions.

12. With the anchor ballasts stabilized by 6 inches (150 mm) of compacted backfill, tension the strap to eliminate all slack using the ratchet. The tension should make the strap tight, without displacing the precast concrete plate anchor ballasts or damaging the tank.

13. Do not over tighten the straps.

14. Complete backfilling the tank as described in the Infiltrator IM- and CM-Series Tank Installation Instructions.

### Step 3-3: Helical Anchors and Anchor-Lock Assemblies

Helical anchors and anchor-lock assemblies may be installed as buoyancy control systems. For both types of system described below, refer to the equipment manufacturer's installation instructions for details on how to use and install the specified products. For helical and anchor-lock systems other than those described below, use Step 3-5: Custom-Designed Buoyancy Controls and Table 2 to determine the required pullout force per anchor and the manufacturer's literature to determine the required product model and installation requirements.



• Chance™ No-Wrench Screw Anchors – The Chance helical anchor shall have a 6-inch (150 mm) diameter helix, Class 7, or equal. These anchors rely on the shear strength of the soil combined with the weight of the soil above the anchor helix to provide holding strength. Proper installation is to 4 ft (1.2 m) below the bottom of the tank excavation and to within 5° of alignment with the strap alignment. Helical anchors should be installed so that the eye loop is level with the bottom of the tank excavation. Determine the proper locations for anchor installation to ensure that tie-down straps will be aligned properly for each tank model (Figure 10). Never place helical anchors beneath the outermost footprint of the tank, including beneath the tank haunches. Follow the anchor manufacturer installation and testing instructions.

• DuckBill® Anchor-Lock Assembly – DuckBill models are shown for each tank model in Table 4 below. These anchors rely on the shear strength of the soil combined with the weight of the soil above the anchor to provide holding strength. Determine the proper locations for anchor installation to ensure that tie-down straps will be aligned properly for each tank model (Figure 10). The system installer shall determine the DuckBill assembly materials of manufacture for the specified model. Polyester straps shall be connected to the DuckBill anchor wire assembly such that the wire assembly is not in contact with the tank body. Never place anchor-lock assemblies beneath the outermost footprint of the tank, including beneath the tank haunches. Follow the anchor manufacturer installation and testing instructions.

**Table 4: Anchor-lock Assembly Specifications**

Tank Model	DuckBill Assembly
IM-540	Model 40
IM-1060	Model 68
CM-1060	Model 68
IM-1530	Model 88

**⚠ WARNING: Do Not Use Cable Tie-Downs: The use of cables to connect anchor ballasts in lieu of strapping is prohibited. Cables concentrate the load exerted by the buoyancy control system within a small area on the tank surface, resulting in the potential to damage the tank. Cable may damage the tank.**

### Step 3-4: Concrete Collar Anchor Ballast

The concrete-collar anchor ballast option includes a cast-in-place concrete ring along the perimeter of the mid-height seam (Figure 9). Cast-in-place concrete shall be a minimum 3,000 psi (20.7 MPa) compressive strength at 28 days and minimum 6% air entrainment. Concrete shall be cast in contact with the exterior surface of the tank to allow interlock with sidewall ribs and the mid-height seam. Reinforcing steel is not required, but may be added if desired. The concrete collar shall be continuous around the entire tank perimeter.

**Figure 9: Concrete Collar Anchor Ballast**

END VIEW

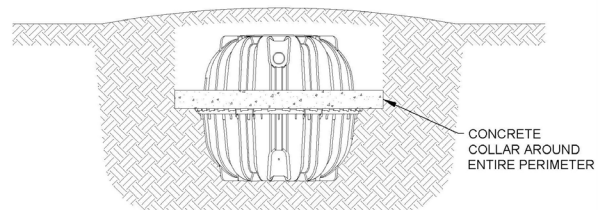

Concrete collar anchor ballast installation should be as follows:

1. Backfill the tank to the mid-seam area in accordance with the Infiltrator IM- and CM-Series Tank Installation Instructions.
2. If reinforcing steel is being used, place reinforcing bars in the desired location.
3. Pour concrete in contact with the exterior surface of the tank to create an interlocking connection with tank sidewall ribs and the mid-height flange.
4. Pour concrete such that the bottom of the collar is located at the top of the mid-seam flange of the tank.
5. Pour concrete such that the collar width and height conform with Table 2 minimum dimensional specifications.
6. Allow sufficient curing of the concrete to prevent damage to the concrete collar before completing the tank backfilling process.
7. Backfill in accordance with the Infiltrator IM- and CM-Series Tank Installation Instructions.

### Step 3-5: Custom-Designed Buoyancy Controls

Table 2 includes a column listing minimum supplemental downward forces to allow custom-designed buoyancy controls not described in this guidance document. Possible custom-designed anchor ballasts include, but are not limited to, precast and cast-in-place concrete blocks, traffic barriers, concrete-filled half pipe, and a concrete slab. Note that the Table 2 values include a suggested 1.5 factor of safety applied to the calculated minimum downward force required to restrain the tank and assumes the subsurface water level is positioned 44 inches above the tank bottom.

Custom-designed buoyancy control methods must consider the effect of saturated soil conditions on the tank and custom-designed buoyancy control mechanism. As long as buoyancy control is provided that supplies the minimum downward force listed in Table 2, the tank is calculated to be stable for the subsurface water level outside the tank and above the tank bottom and corresponding soil cover conditions.

All Infiltrator strapping, fastening, and anchor ballast positioning recommendations and the Infiltrator IM- and CM-Series Tank Installation Instructions apply for custom-designed buoyancy control methods. Since custom-designed buoyancy controls may rely on the weight of the anchor ballast, the weight of soil column over the anchor ballast, a combination of anchor ballast and soil weight, or anchor pullout resistance, anchor placement and installation must account for its functional design. Never place any portion of the anchor ballasts beneath the outermost footprint of the tank, including beneath the tank haunches. Design and installation methods shall be determined by the installer.

Contact Infiltrator's Technical Services Department with any questions regarding supplemental downward force requirements.

**⚠ WARNING: Do Not Use Geogrid-Based Buoyancy Controls**  
**Some tank manufacturers endorse the use of buoyancy control systems incorporating geogrid draped across the tank connected to an anchor ballast system or anchored within soil around the tank. Infiltrator has determined that the use of geogrid buoyancy control systems is unacceptable with IM- and CM-Series tanks. Infiltrator advises against the use of geogrid-based tank restraint systems for IM- and CM-Series tanks. The presence of the geogrid across the tank top and sides prevents the proper placement and compaction of soil between the tank-body corrugations and beneath the tank haunches, as required per the Infiltrator IM- and CM-Series Tank Installation Instructions.**

### Supplemental Technical Guidance

Supplemental technical guidance is provided below for use with the five buoyancy control methods described in Step 3.

#### Excavation Requirements

The excavation width should provide a minimum of 36 inches (900 mm) clearance beyond the tank on all sides when utilizing buoyancy control. This will allow sufficient space within the excavation to place anchoring equipment and fasten strapping. The excavation should provide a minimum 48-inch (1,200 mm) clearance beyond the tank when using helical- and anchor-lock-type anchors to allow for sufficient space to properly install the anchoring system. The actual excavation size shall be determined by the installer. Refer to Infiltrator IM- and CM-Series Tank Installation Instructions for additional excavation procedures.

**⚠ WARNING: Never place any portion of the anchor ballasts beneath the outermost footprint of the tank, including beneath the haunches.**

#### Short And Long-Term Groundwater Control

It may be necessary to implement groundwater control measures during tank installation. Maintain dry conditions by expanding the excavation to create a short-term groundwater collection sump for temporary placement

of a dewatering pump if needed. Long-term groundwater control measures such as underdrains and interceptor trenches may be sensible if the site is amenable to construction of a control system and such systems are not prohibited by regulation or law, and the tank location is not subject to flooding. Underdrains and groundwater interceptor trenches may prevent the need for tank buoyancy control measures.

### Ratchet Strap Material Specifications



The configuration and capacity of the four-strap Infiltrator Tank Buoyancy Control Strap Assembly (TANK-BCS-KIT) is designed to be compatible with both the beam and precast concrete plate buoyancy control options shown in Table 2. If using a beam anchor ballast, all four straps are required to complete the installation. If using a precast concrete plate anchor ballast, only the 14-ft-long (4.3 m) strap with hooked end and ratchet strap with hooked end are required, with connection directly to the precast concrete plate hardware, thereby eliminating the need for the 5-ft-long (1.5 m) looped-end straps.

Off-the-shelf, commercially available strap systems can also be used for beam and precast concrete plate buoyancy control options shown in Table 2. For the beam anchor ballasts, a commercially available four-strap system (two hooked-end straps, two looped-end straps) is recommended for connecting the anchor ballasts to the tank. For the precast concrete plate anchor ballast, a commercially available two-strap system (two hooked-end straps) is recommended for connecting the anchor ballasts to the tank. The suggested strap configuration is as follows:

- Two 5-ft-long (1.5 m) straps with sewn, looped ends (applies to beam only)
- One 14-ft-long (4.3 m) strap with a hooked end
- One ratchet strap with hooked end

For commercially available strap systems, the recommended method of strap tightening is a ratchet, which is used to remove all slack and slightly pre-load the system. All connections, fittings, and hardware must be corrosion resistant (stainless steel or galvanized) or coated with epoxy or other corrosion-resistant materials to inhibit deterioration in the subsurface environment. If not using stainless steel or galvanized components, apply a corrosion-resistant coating prior to burial. The recommended strap and ratchet specifications for commercially available strap system components are as follows:

- Strap width: 2 in (5 cm)
- Strap material: Polyester
- Strap minimum working load limit: 3,300 lbs (1,500 kg)
- Strap assembly break strength: 10,000 lbs (4,538 kg)
- Strap hooks: Stainless steel
- Strap tightening mechanism: Stainless steel ratchet
- Ratchet working capacity: 10,000 lbs (4,538 kg)

Strap materials and capacity are the same for helical anchors and anchor-lock assemblies. The strap length and connection configuration and hardware may differ depending upon the type of anchor ballast system being used.

**⚠ WARNING: Do Not Use Cable Tie-Downs: The use of cables to connect anchor ballasts in lieu of strapping is prohibited. Cables concentrate the load exerted by the buoyancy control system within a small area on the tank surface, resulting in the potential to damage to the tank.**

### Ratchet Strap Placement

Proper installation of straps over the tank is critical for tank stability under changing conditions both inside and outside the tank. Straps must be placed at the specified strapping locations for each tank model, as illustrated in Figure 10. Strapping locations are embossed on the exterior surface of the tank. Strapping locations correspond to structurally reinforced areas of the tank body. Straps must never be placed over access openings, lids, or inlet/outlet piping. The ratchet must be positioned below the tank midseam so it is not in contact with the tank body. Straps must be tightened with a ratchet to remove slack and slightly pre-load the system, without displacing the connected anchor ballasts or damaging the tank.

### Strapping Notes:

1. Beam anchor ballasts shall be centered across the straps. Concrete plate and helical anchor and anchor-lock ballasts shall be aligned with the strap installation location embossed on the tank exterior.
2. Beam anchor ballasts shall extend a minimum of 6 inches (150 mm) beyond the maximum strap width.
3. When applicable in Table 2, the minimum beam anchor ballast length corresponds to the tank model-specific strap width plus 12 inches (300 mm).

Figure 10: Strap Positioning

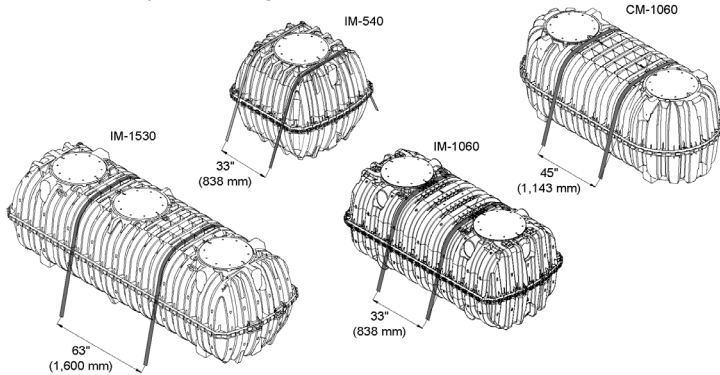

**⚠ WARNING: Do Not Use Cable Tie-Downs: The use of cables to connect anchor ballasts in lieu of strapping is prohibited. Cables concentrate the load exerted by the buoyancy control system within a small area on the tank surface, resulting in the potential to damage to the tank.**

### Backfilling

A critical aspect of tank installation is proper backfilling. At a minimum, compacted soil must be present: 1) between the tank-body corrugations; 2) beneath the tank haunches; and 3) around and above the anchor ballasts (Figure 11). Backfill shall consist of compacted, suitable soil placed in lifts no greater than 12 inches (300 mm), as described in the Infiltrator IM- and CM-Series Tank Installation Instructions.

Figure 11: Backfill Placement

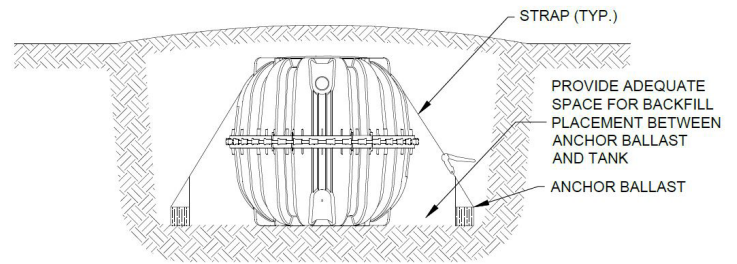

**⚠ WARNING: Use of Tank Installation Instructions: This guidance document provides general statements on backfilling and tank installation only. Refer to the Infiltrator IM- and CM-Series Tank Installation Instructions for complete tank installation requirements.**

Note: Infiltrator tanks do not require filling with water prior to backfill placement. Water filling and backfilling to the tank mid-height is required if the tank is left in either an open or backfilled excavation that may fill with water from precipitation or other sources.

### Parts and Supplies

The parts and supplies necessary are to be purchased separately from the tank. All parts and supplies are either commercially available or available through Infiltrator's network of tank distributors. Some parts may require fabrication on site using common construction practices.

### General Information

- Refer to the Infiltrator IM- and CM-Series Tank Installation Instructions for complete information on tank installation requirements. Failure to comply with installation instructions will void the warranty.
- Prior to ground disturbance, check for subsurface obstructions and utilities in conformance with applicable regulatory requirements.
- Excavation safety provisions shall conform to applicable government regulations.
- Follow manufacturer instructions for all products and devices used for Infiltrator tank buoyancy control.
- Buoyancy control methods described herein do not account for unanticipated conditions such as surface flooding, temporary inundation or other natural occurrences, unintended removal of cover fill over tank, etc.
- Buoyancy control methods described herein are recommendations only; consult a professional engineer for customized designs, if desired.

**Infiltrator Water Technologies, LLC (“Infiltrator”)  
INFILTRATOR® SEPTIC TANK LIMITED WARRANTY FIVE (5) YEAR  
MATERIALS AND WORKMANSHIP LIMITED WARRANTY**

- (a) This limited warranty is extended to the end user of an Infiltrator Tank. A Tank manufactured by Infiltrator, when installed and operated in accordance with Infiltrator’s installation instructions and local regulation by a person or company that is properly qualified to install the Infiltrator tank in accordance with applicable state and/or local requirements, is warranted to you: (i) against defective materials and workmanship for five (5) years after installation. Infiltrator will, at its option, (i) repair the defective product or (ii) replace the defective materials. Infiltrator’s liability specifically excludes the cost of removal and/or installation of the Tank.
- (b) In order to exercise its warranty rights, you must notify Infiltrator in writing at its corporate headquarters in Old Saybrook, Connecticut within fifteen (15) days of the alleged defect.
- (c) YOUR EXCLUSIVE REMEDY WITH RESPECT TO ANY AND ALL LOSSES OR DAMAGES RESULTING FROM ANY CAUSE WHATSOEVER SHALL BE SPECIFIED IN SUBPARAGRAPH (a) ABOVE. INFILTRATOR SHALL IN NO EVENT BE LIABLE FOR ANY CONSEQUENTIAL OR INCIDENTAL DAMAGES OF ANY KIND, HOWEVER OCCASIONED, WHETHER BY NEGLIGENCE OR OTHERWISE. SOME STATES DO NOT ALLOW THE EXCLUSION OR LIMITATION OF INCIDENTAL OR CONSEQUENTIAL DAMAGES, SO THIS LIMITATION OR EXCLUSION MAY NOT APPLY TO YOU. THIS WARRANTY GIVES YOU SPECIFIC LEGAL RIGHTS AND YOU MAY ALSO HAVE OTHER RIGHTS WHICH VARY FROM STATE TO STATE.
- (d) THIS LIMITED WARRANTY IS THE EXCLUSIVE WARRANTY GIVEN BY INFILTRATOR AND SUPERSEDES ANY PRIOR, CONTRARY, ADDITIONAL, OR SUBSEQUENT REPRESENTATIONS, WHETHER ORAL OR WRITTEN. INFILTRATOR DISCLAIMS AND EXCLUDES TO THE GREATEST EXTENT ALLOWED BY LAW ALL OTHER WARRANTIES, WHETHER EXPRESS OR IMPLIED, OR STATUTORY, INCLUDING ANY WARRANTY OF MERCHANTABILITY, FITNESS FOR A PARTICULAR PURPOSE AND ANY IMPLIED WARRANTIES OTHERWISE ARISING FROM COURSE OF DEALING, COURSE OF PERFORMANCE, OR USAGE OF TRADE. NO PERSON (INCLUDING ANY EMPLOYEE, AGENT, DEALER, OR REPRESENTATIVE) IS AUTHORIZED TO MAKE ANY REPRESENTATION OR WARRANTY CONCERNING THIS PRODUCT, EXCEPT TO REFER YOU TO THIS LIMITED WARRANTY. EXCEPT AS EXPRESSLY SET FORTH HEREIN, THIS WARRANTY IS NOT A WARRANTY OF FUTURE PERFORMANCE, BUT ONLY A WARRANTY TO REPAIR OR REPLACE.
- (e) YOU MAY ASSIGN THIS LIMITED WARRANTY TO A SUBSEQUENT PURCHASER OF YOUR HOME.
- (f) NO REPRESENTATIVE OF INFILTRATOR HAS THE AUTHORITY TO CHANGE THIS LIMITED WARRANTY IN ANY MANNER WHATSOEVER, OR TO EXTEND THIS LIMITED WARRANTY.
- (g) NO WARRANTY OF ANY KIND IS MADE WITH REGARD TO ANY PRODUCT, COMPONENTS, DEVICES, MEDIA OR TREATMENT UNITS WHICH ARE MANUFACTURED BY OTHERS AND ARE INSTALLED IN AN INFILTRATOR TANK. USE OF THESE PRODUCTS ARE AT YOUR OWN RISK.
- (h) THE INFILTRATOR TANK IS DESIGNED TO BE BURIED UNDERGROUND. NO WARRANTY OF ANY KIND IS MADE IF YOUR TANK IS NOT BURIED UNDERGROUND AS SPECIFIED IN THE PRODUCT’S INSTALLATION INSTRUCTIONS.

**CONDITIONS AND EXCLUSIONS**

There are certain conditions or applications over which Infiltrator has no control. Defects or problems as a result of such conditions or applications are not the responsibility of Infiltrator and are NOT covered under this warranty. They include failure to install the Tank in accordance with instructions or applicable regulatory requirements or guidance, altering the Tank contrary to the installation instructions and disposing of chemicals or other materials contrary to normal tank usage.

The above represents the Standard Limited Warranty offered by Infiltrator. A limited number of regulatory jurisdictions have different warranty requirements. Any purchaser of a Tank should contact Infiltrator’s corporate headquarters in Old Saybrook, Connecticut, prior to such purchase to obtain a copy of the applicable warranty, and should carefully read that warranty prior to the purchase of a Tank.



4 Business Park Road  
P.O. Box 768  
Old Saybrook, CT 06475  
860-577-7000 • Fax 860-577-7001  
1-800-221-4436  
[www.infiltratorwater.com](http://www.infiltratorwater.com) • [info@infiltratorwater.com](mailto:info@infiltratorwater.com)

U.S. Patents: 8322948; 8337119; 8297880; 7914230; 7008138. Other patents pending. Infiltrator, Quick4 and EZflow are registered trademarks of Infiltrator Water Technologies. Infiltrator Water Technologies is a wholly-owned subsidiary of Advanced Drainage Systems, Inc. (ADS).

© 2022 Infiltrator Water Technologies, LLC. Not responsible for any typographic errors. Printed in U.S.A.

TANK03 0622

**Contact Infiltrator Water Technologies’ Technical Services Department for assistance at 1-800-221-4436**