



# PROCEDURES FOR ASSEMBLY AND INSTALLATION

(500-600 GPD SYBR-AER FT SERIES)

SBR WASTEWATER TECHNOLOGIES INC.

1501 COMMERCE CENTER DRIVE

FRANKLIN, OHIO

TEL: 937-790-4149

FAX: 937-790-4150

WWW.SBRWW.COM

Thank you for purchasing the Sybr-Aer advanced wastewater treatment system. The following will provide step-by-step installation instructions.

The SYBR-AER FT series comes with all components factory installed for ease of installation. The Unit is also pre-wired and comes with 100' of direct burial 12 conductor wire ( If your application requires a longer run of wire please let us know at time of order).

The SYBR-AER FT series comes with or without disinfection depending on your application. The following instructions address both versions.

The SYBR-AER FT Series contains:

- Vented fiberglass blower enclosure with electrical junction box, cord grips, gel coated cover and exterior tamper proof latches
- (2) 24" diameter risers with pre-installed air manifolds, (2) covers
- (1) float tree
- (1) blower with galvanized fittings, air filter, and mission couplings
- (1) discharge pump with quick disconnect fittings, floats and pedestal
- Engineered diffusers
- 1 1/2" air drops with quick disconnect fittings
- Outdoor alarm with logic control module, individual circuit breakers for service disconnect, and a battery back-up incase of power outage
- 100' twelve-conductor direct burial wire
- conduit with a sweep for control panel
- Fiberglass tank with lifting eyelits
- (F2-UV disinfection system if you are using disinfection)



## SYBR-AER FT SERIES INSTRUCTIONS

*The installation must comply with all state and local regulations.*

### SITE PREPARATION

#### LOCATION

The site plan should show the desired location of the waste treatment plant and the location of the effluent disposal system. **CAUTION:** Check to make sure the site plan accurately reflects the conditions actually existing at the site and that all required set-backs (i.e., to wells, property lines, etc.) are being met.

#### GRADE AND GROUND COUNTOUR

Position the waste treatment plant so that surface water and effluent will drain to a lower grade under all known conditions.

#### COVER EXPOSURE

The access covers must be exposed at all times to permit the system to function properly and to allow for routine maintenance. There should be a minimum of (2) two inches between the bottom of the lid and the finished grade.

#### BUILDING SEWER LINE

Carefully check all elevations to insure that the building sewer will have the proper fall (slope) to meet the inlet of the **SYBR-AER** and maintain the grade requirements to insure proper exposure of the cover. The elevation of the outlet should also be checked to insure proper elevation of the effluent disposal system.

#### EXCAVATION PREPARATION

Clear an area at least two (2) feet larger than the dimensions of the tank, which is to be installed.

Determine the required depth of the excavation based upon the elevation of the invert of the inlet sewer line or the elevation of the finished grade.

**NOTE: Riser needs are built into the tank. There is 13 inches of adjustment built into the tank. Locate the proper elevation and drill a 5" inlet hole on the flat section of the tank and install the supplied 4" gasket seal**



Excavate a hole approximately two (2) feet wider than the perimeter of the plant.

**NOTE:**

If the final elevations will not allow for the proper installation of the SYBR-AER, a lift station can be installed upstream.

Care should be taken to not dig too large (or too deep) of a hole. If the hole is dug too deep, fill in the bottom of the excavation with a minimum of 6" of sand, pea gravel or crushed stone to the required bottom depth. **This material should be well compacted to prevent settling of the tank when it is filled with water.**

**OFF-LOADING AND UNPACKING**

The SYBR-AER FT Series comes with four lifting eyelits to lift the tank.

**NOTE:** Be sure to use all four lifting eyelits for safety when moving the tank and that your lifting harness is long enough not to pinch the blower housing.

**Caution:** Unit is top heavy move with care.



**BACKFILLING**

Once the tank is set and leveled start filling the tank with water and begin backfilling with friable material up to the inlet. Firmly insert the inlet pipe into the tank. (pipe lube recommended)

**CAUTION:** To prevent any damage to the inlet or outlet pipes due to settling or backfilling, make sure that both inlet and outlet pipes are set on undisturbed or firmly-packed fill material prior to final backfilling procedures.



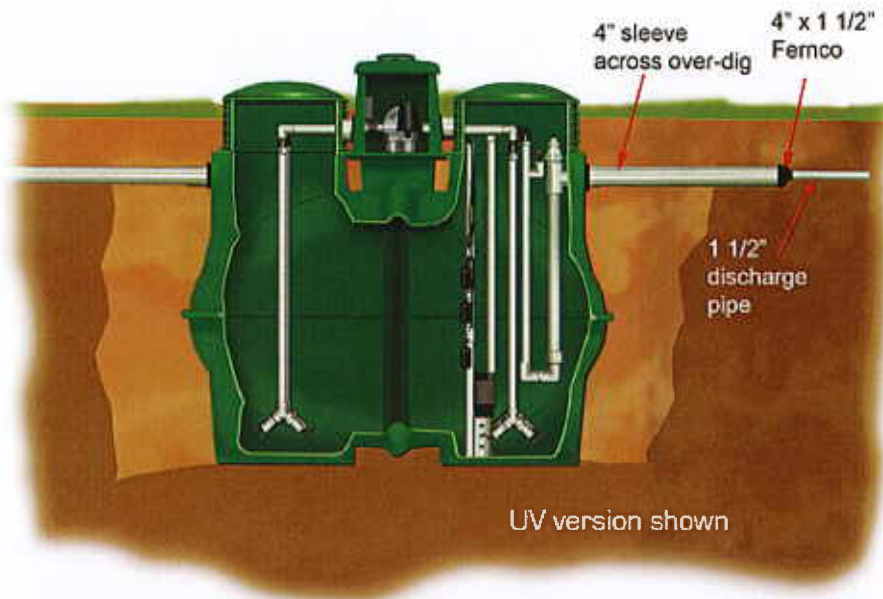

Once you have slid the discharge pipe through the protective sleeve ( 4" piece of pipe long enough to span across the over-dig) and connected it to the pump line, install the supplied 4"x 1 1/2" Fernco on the end of the 4" pipe in the trench to prevent ground water from entering the pipe. The protective sleeve provides protection during backfilling and eliminates the chance of sheering off the pipe if the tank settles.

## ELECTRICAL

**NOTE: SBC4080UV Control Panel requires 2 dedicated circuits to power the panel (with UV)  
SBC4060 Control Panel requires 1 dedicated circuit to power the panel (without UV)**

All the components for the SYBR-AER are pre-installed and pre-wired so no need to make any electrical connections at the tank. Run the 100' of direct burial cable supplied to the location you want to mount the control panel.

Use care and drill control panel box for 1" conduit. ( Make sure you do not drill into the terminal strip in the bottom of the panel.) Mount the control panel with the supplied hardware and install the conduit and sweep.

Feed the 12 wire through the conduit and into the panel.



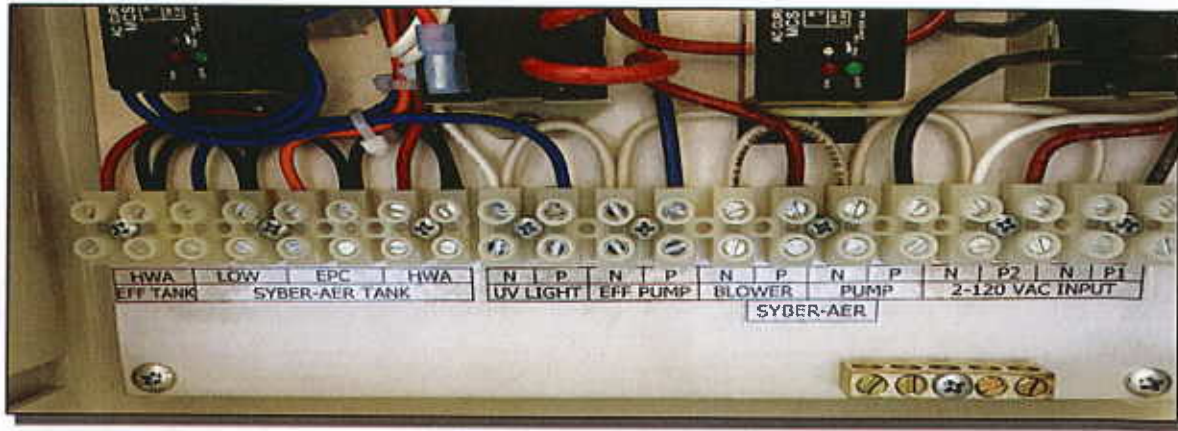

The control panel is clearly labeled and utilizes terminal blocks so no need for wirenuts.

Wiring instructions are listed on backside of control panel access door.

### **SBC 4060 (NON UV)**

SOLID RED TO BLOWER POWER  
 RED W/STRIPE TO BLOWER NEUTRAL  
 SOLID BLACK TO PUMP POWER  
 BLACK W/STRIPE TO PUMP NEUTRAL  
 SOLID YELLOW TO E.P.C. FLOAT POWER  
 YELLOW W/STRIPE TO E.P.C. FLOAT NEUTRAL  
 SOLID ORANGE TO HIGH WATER FLOAT POWER  
 ORANGE W/STRIPE TO HIGH WATER NEUTRAL  
 SOLID BROWN TO GROUND BAR  
 BROWN W/STRIPE TO GROUND BAR

\* 2-BLUE WIRES NOT USED

### **SBC 4080UV (WITH UV)**

SOLID BLUE TO UV POWER  
 BLUE W/STRIPE TO UV NEUTRAL  
 SOLID RED TO BLOWER POWER  
 RED W/STRIPE TO BLOWER NEUTRAL  
 SOLID BLACK TO PUMP POWER  
 BLACK W/STRIPE TO PUMP NEUTRAL  
 SOLID YELLOW TO E.P.C. FLOAT POWER  
 YELLOW W/STRIPE TO E.P.C. FLOAT NEUTRAL  
 SOLID ORANGE TO HIGH WATER FLOAT POWER  
 ORANGE W/STRIPE TO HIGH WATER NEUTRAL  
 SOLID BROWN TO GROUND BAR  
 BROWN W/STRIPE TO GROUND BAR

Once all connections are made power can be supplied to the panel. Turn on all the Breakers. Press and hold the test button to activate the alarm.



Remove the discharge side lid and unhook and raise the float tree up out of the tank and cut the shipping tape off of the floats. [Floats are taped to float tree for shipping purposes and failure to remove tape will prevent system from operating properly]



**Top Float is the E.P.C. Float**  
**Middle Float is the Highwater Float**  
**Bottom Float is the Redundant ON/OFF Float**

[Low alarm is an optional alarm it is designed for a float to be set low so that when the tank pumps out if it is still up it will go into a latching alarm to alert you it didn't pump out enough]

Raise the highwater float and make sure alarm sounds. With the blower running raise the E.P.C. float and make sure the blower shuts off. Raise the Redundant ON/OFF float and flip the manual pump run switch in the panel and make sure the pump runs.

**NOTE: The E.P.C. will shut the blower off and start a 1 hour settling cycle then run the pump. To clear this alarm once you activated the float shut the power breaker off to clear the alarm condition then turn back on**



Turn the Blower Breaker off and make sure the alarm activates then turn breaker back on. If the system has enough water in it you can let it run or turn it off until you are finished with the installation.

Once everything has been tested and operational install lids and continue backfilling. Finish backfilling to a level approximately 2" below the access lid. Finish Grade should be contoured so that surface water drains away from the unit.

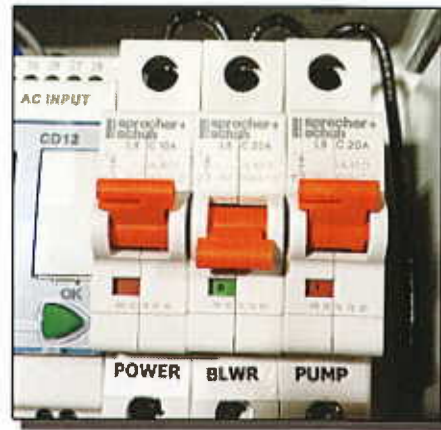

**The following instructions are for units with Ultraviolet Light.**

The quartz tube is shipped inside the UV housing. Loosen the large union and remove quartz tube to remove protective packaging.

**Note:** Failure to remove packaging from the quartz tube will prevent proper operation and will not allow the system to discharge properly.



The UV Bulb is transported in a tube taped to the float tree. Carefully cut the tube free from the float tree and open to remove bulb.

**NOTE:** Care should be taken to not touch the glass of the bulb if you are not wearing gloves. Oil from your skin can create hot spots on the bulb and shorten the life of the bulb.





Once the packaging has been removed re-install the quartz tube and tighten down the Large union



Plug the UV Whip (chord) onto the uv bulb and lower into the quartz tube

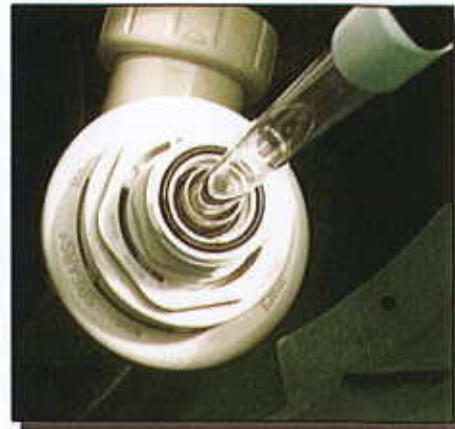

Tighten down the small union



The UV is designed to treat up to 14 gallons a minute. In the SYBR-AER FT Series we set the ball-valve to 10 gallons a minute to simplify adjusting the flow ( adjusted flow should fill a 5 gallon bucket in 30 seconds).



Once the UV light is hooked up turn the UV breaker on. Flip the sample mode switch this shuts the blower off and turns the UV on you should see the current switch on the left in the panel light up red when the UV comes on as well as listed on the operating screen of the logic module. Shut the UV Light breaker off and the alarm should sound turn the breaker back on and clear the alarm .Once this is verified turn the sample mode switch off this puts it back into normal operation



**NOTE: Blower will not operate if sample switch is left in the ON position.**

The control panel is programmed to turn the UV light on when the Blower turns off and goes into settle mode at midnight. In normal operation the UV light is only on 4 hours a day. If the system goes into a highwater situation and the homeowner continues to use water and triggers the E.P.C. float the blower will turn off and turn the UV light on for a 1 hour settle mode and then pump the excess water out.

The control panel is failsafed in the event of a blower or UV light failure the pump is locked out and will not discharge until the alarm condition has been cleared.

**CAUTION: Do not look at UV Light when it is on can damage eyes.**



## POST AERATION (IF REQUIRED)

Re-aeration is achieved by spraying effluent against a surface when pumped effluent is drawn from the tank. The effluent pump discharges through a perforated fitting into a standard 16"x16"x14" Tuf-Tite polyethylene distribution box prior to discharge. The vigorous spraying provides sufficient agitation to raise the dissolved oxygen level to almost saturated concentrations

\* **NOTE:** Mark the ball-valve in the discharge line then adjust in order to slow the flow enough to take a freeflowing sample once sample is taken return the ball valve to it's original position

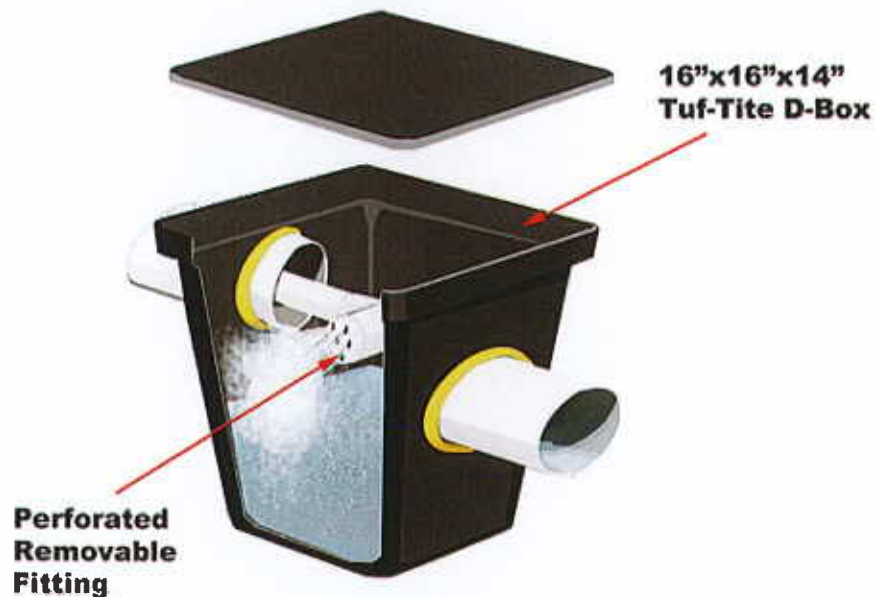

Once the installation is complete be sure to give the property owner the owners manual, explain the Do's and Dont's, and fill out and send in the installation report

**TANK INFORMATION**

| <b>S-A 1250 FIBERGLASS TANK</b>                                   |                            |
|---|----------------------------|
| <b>MATERIALS</b>  | Glass-Reinforced Polyester |
| <b>TOTAL CAPACITY</b>   | 1,499 GAL                  |
| <b>LENGTH</b>   | 96 INCHES                  |
| <b>WIDTH</b>  | 86 INCHES                  |
| <b>HEIGHT</b>   | 69 INCHES                  |
| <b>MANWAYS</b>  | 24"                        |
| <b>INLET INVERT</b>   | 57"-70"                    |
| <b>OUTLET INVERT</b>  | 67.5 INCHES                |
| <b>COMPARTMENTS</b>   | ONE                        |
| <b>MAXIMUM BURIAL DEPTH</b>                                       | 24 INCHES                  |
| <b>MAXIMUM PIPE DIAMETER</b>                                      | 4"                         |
| <b>JOINT SEALANT</b>  | Consol CS-102 or equal     |
| <b>WEIGHT</b>   | 590 LBS                    |
| <b>DISPLACED WEIGHT</b><br><i>(assuming saturated conditions)</i> | 12506.7 LBS.               |
| <b>BUOYANCY FORCE</b>   | 11916.7 LBS.               |

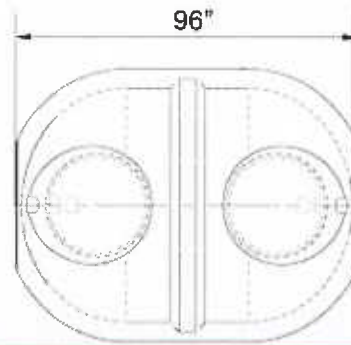

**TOP VIEW**

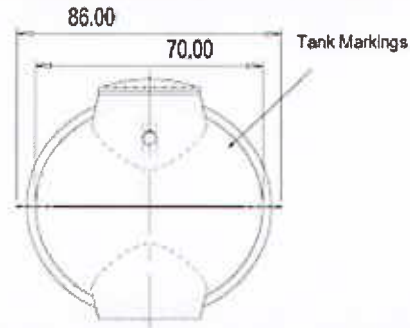

**END VIEW**

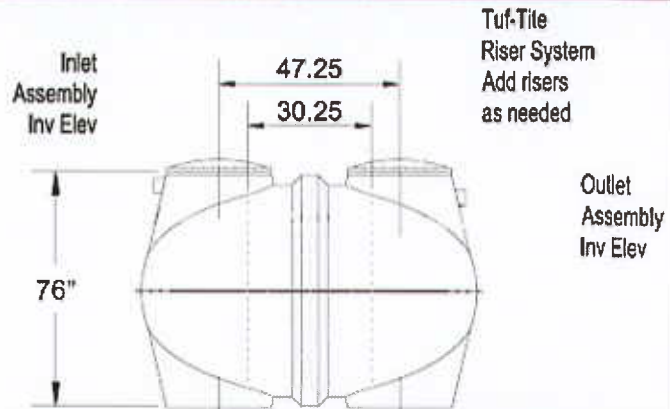

**SIDE VIEW**



|   |                |
|---|----------------|
| <b>S-A 1250 FIBERGLASS TANK</b>   |                |
| <b>TITLE:</b>   | <b>1250 SA</b> |
|                      |                |
| <small>TREATMENT SYSTEMS<br/>1501 Commerce Center Drive<br/>Franklin, Ohio 45005<br/>937-748-2727</small> |                |



**TANK INFORMATION**

| <b>BOYANCY DESIGN</b>                               |          | 1250 S-A<br>Tank |
|---|----------|------------------|
| <b>Materials</b>                                    |          |                  |
| Soil (dry)  | (lbs/cf) | 90.0             |
| Void Ratio  | %        | 28.00%           |
| Water   | (lbs/cf) | 62.4             |
| Saturated Soil                                      | (lbs/cf) | 107.5            |
| Soil (net)  | (lbs/cf) | 72.5             |
| Concrete  | (lbs/cf) | 150.0            |
| <b>Tank Data</b>                                    |          |                  |
| Tank Weight   | (lbs)    | 590              |
| Volume  | (gal)    | 1499.2           |
| Volume  | (cf)     | 200.4            |
| Displaced Weight<br>(assuming saturated conditions) | (lbs)    | 12506.7          |
| Boyant Force<br>(less manways)                      | (lbs)    | 12022.7          |
| Tank Projected Area                                 | (sf)     | 53.0             |
| Cover required w/o<br>Deadman                       | (in)     | 37.5             |
| <b>Deadman Data</b>                                 |          |                  |
| Deadman Weight                                      | (lbs)    | 300              |
| Deadman Area  | (sf)     | 4.0              |
| Deadman Burial Depth                                | (in)     | 75.0             |
| Deadman Hold Down<br>Force / each                   | (lbs)    | 2112.5           |
| Number of Deadman                                   | (ea)     | 4                |
| Minimum Required Tank<br>Covering                   | (in)     | 11.2             |

**Recommended SYBR-AER Installation Check List**

|              |                      |
|--------------|----------------------|
| Date:        | Installer:           |
| Permit:      | Site Address:        |
| Property ID: | Site City and State: |

| Item                                    |     |    | Item  |     |    |
|---|-----|----|---|-----|----|
| <b>Administrative Issues</b>            |     |    | <b>Excavation and Installation</b>            | Yes | No |
| Permit On Site                          | Yes | No | Level Excavation                              | Yes | No |
| Site Protected from Traffic             | Yes | No | Bedding Stone Used if rocks present           | Yes | No |
| Benchmark and Baseline                  | Yes | No | Correct Excavation Elevation                  | Yes | No |
|   |     |    | Level Installation                            | Yes | No |
|   |     |    | Backfill is clean and friable and compacted   | Yes | No |
| <b>Electrical Installation</b>          |     |    | Grade runs away from access lids              | Yes | No |
| Power Cords Run Through Fittings        | Yes | No | Inlet and Outlet Pipes Connected              | Yes | No |
| Watertight Wire Nuts Used               | Yes | No | Treatment Tank Filled                         | Yes | No |
| Alarm Installed Per Code                | Yes | No | Lid 2' Min. Above Grade                       | Yes | No |
| Alarm Tested and Functioning            | Yes | No | <b>Internal Components</b>                    | Yes | No |
|   |     |    | Blower Installed and Operating                | Yes | No |
| <b>Final</b>                            |     |    | Airline drop legs Installed                   | Yes | No |
| Installation Conforms to Approved Plans | Yes | No | Pump and pump pipe Installed                  | Yes | No |
|   |     |    | UV Light installed and operating (if present) | Yes | No |
|   |     |    | Alarm Installed and Operating                 | Yes | No |
|   |     |    | Lids Installed and Secured                    | Yes | No |
|   |     |    | Service contact info provided                 | Yes | No |
|   |     |    | Owner's manual left with property owner       | Yes | No |

Note: On the backside, make a sketch of the installation noting differences between the plan and actual installation.

Comments and Notes:

---



---



---



---



---



---



---



---

## **Service Policy**

During your initial two-year warranty, an authorized service representative will inspect your unit at six-month intervals and make necessary adjustments to the system. The only exception is for the replacement of "out of warranty" and "physically abused" parts or abuse to the treatment and dispersal components and devices, such as pre-tanks, drain fields, pump station, and the like.

In the event a problem arises or service is required, refer to the unit's data plate (located on the alarm and access lid) or the service label for instructions on contacting your closest service provider. Occasional pumping is required, due to the accumulation of solids. The pumping cost may not be covered under your maintenance and service program. If you need parts or service, please contact the factory for the name of the service provider nearest you. The owner shall be notified in writing by the service provider about improper system operations that cannot be remedied at the time of the inspection.

Before the initial two-year warranty expires, your service provider will notify you in writing, that an extended service agreement may be purchased. This extended service agreement will have terms, conditions, and limitations comparable to the initial agreement. If the service provider does not provide extended service agreements, the service provider will refer you to an authorized service provider who provides extended service agreements. You may also contact the factory for assistance in locating an authorized service provider.

Items not covered under warranty that will generate service charges for your residential SYBR-AER wastewater treatment equipment.

1. Use of unauthorized component parts in your SYBR-AER unit.
2. Repairs made by other than factory trained and authorized personnel.
3. Failure to maintain proper electric power to the SYBR-AER unit.
4. High water alarms due to clear water discharges including, but not limited to, backwash from water treatment systems, water softeners, swimming pools, footing drain sump pumps, down spouts, hot tubs, dehumidifiers, air conditioners, and leaking plumbing fixtures.
5. Discharge into the SYBR-AER unit of non-biodegradable materials such as paints, grease, or any other materials that are toxic.
6. Emergency service calls for alarms due to items 1 thru 5 above in addition to the following:
  - a. Water usage that exceeds the total daily flow for which your aerobic plant is rated
  - b. The septic system becoming flooded during periods of heavy rainfall.

Listed above are some of the most common items that are not covered by warranty. Specific items not herein listed. Also, please note that the warranty covers parts only. Labor will be billed at the rate in effect at time of service.



## NORMAL OPERATING CYCLE WITH UV

(Non UV same operation minus the UV)

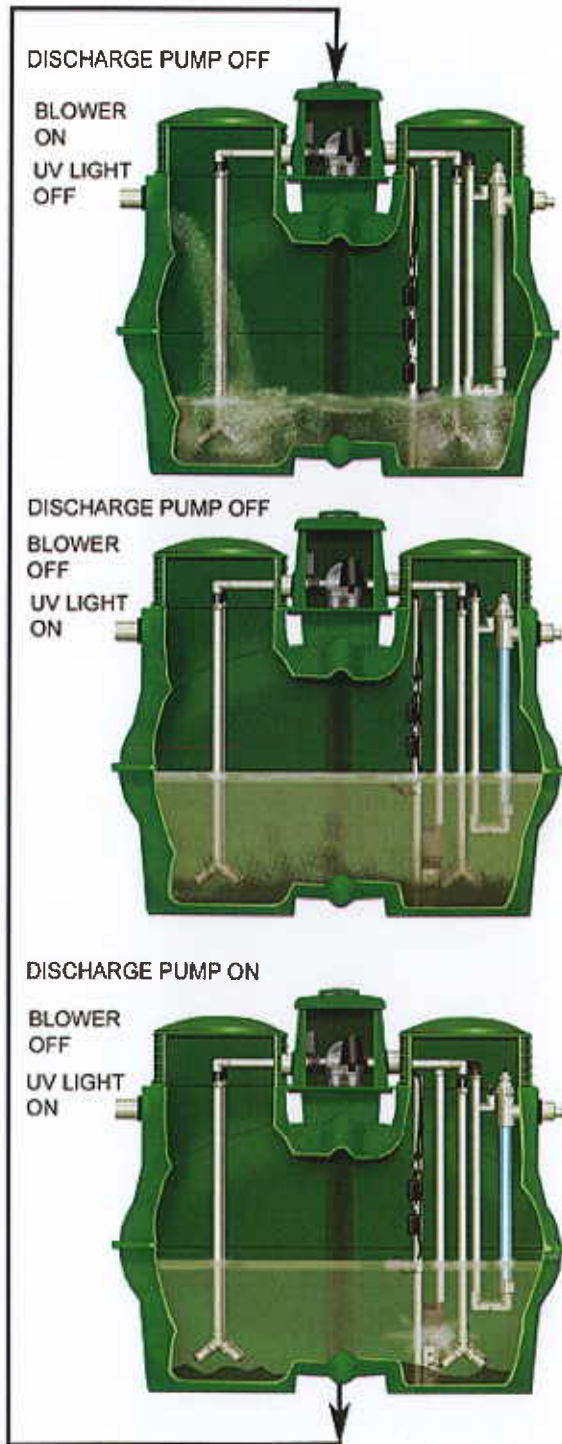

### AERATION CYCLE:

DURATION: 20 HOURS

NORMAL HOURS: 4:00 a.m.-12:00 p.m.

BLOWER: ON DISCHARGE PUMP OFF  
UV: OFF

Description: Aerobic waste treatment occurs during the aeration cycle. Air from the diffusers keeps solids in suspension. This cycle is programmed to occur at normal times of highest water usage.

### SETTLING CYCLE:

DURATION: 3 HOURS

NORMAL HOURS: 12:00 p.m.-3:00 a.m..

BLOWER: OFF DISCHARGE PUMP OFF  
UV: ON

Description: Sludge settles to the bottom of the tank during this cycle. The settling cycle starts when the aeration cycle ends. The settling cycle is programmed to occur during normal times of lowest water usage. When the blower shuts off the UV light turns on.

### PUMP OUT CYCLE:

MAXIMUM DURATION 1 HOUR

NORMAL START TIME: 3:00 a.m..

BLOWER: OFF DISCHARGE PUMP ON  
UV: ON

Description: treated wastewater is pumped through the UV and out of the tank during the pump out cycle. The pump comes on at the end of the settling cycle and runs until the water level in the tank drops to a depth of 19 inches from the bottom of the tank. At this depth a level switch stops the pump.

One hour after the start of the pump cycle, a new aeration cycle begins. The UV light turns off and the blower starts up again.. The entire process is repeated every 24 hours.