

Infiltrator IM-Series Tank Buoyancy Control Guidance

MAY 2019



Before you Begin

This document presents a method for assessing buoyancy control needs for Infiltrator Water Technologies (Infiltrator) IM-Series tanks. Tank buoyancy control measures must be implemented according to state and/or local regulations and approvals, which may supersede these guidelines. If unsure of the requirements for a particular site, contact the local health department or permitting authority.

If tank buoyancy control measures are implemented, refer to Infiltrator IM-Series Tank Installation Instructions and Riser Connection Guidance documents, as applicable, for completing the installation.

How to Use this Document

- Using Step 1, Table 1, and Figures 1 and 2, verify that the level of uninterrupted saturated soil is below the height of the outlet pipe saddle and determine if buoyancy control is required.
- Use the appropriate row in Step 2, Table 2 to determine the minimum buoyancy control methods for the site conditions.
- Once the preferred buoyancy control method is selected, follow the implementation procedures provided in Step 3.

Step 1 -- Determine Need for Buoyancy Control

Required information: (1) maximum height of uninterrupted saturated soil above the tank bottom; and (2) the depth of soil cover above the tank top. Tank buoyancy control may be required if:

- the level of uninterrupted saturated soil outside the tank has the potential to rise 30 inches (750 mm) or more above the bottom of the tank; and
- less than 12 inches (300 mm) of soil cover is to be placed as backfill over the tank top.

NO BUOYANCY CONTROL IS REQUIRED IF THERE ARE AT LEAST 12 INCHES (300 MM) OF SOIL COVER ABOVE THE TANK TOP.

Table 1 Instructions

- In the left-hand column of Table 1, locate the row corresponding to the height of the uninterrupted saturated soil elevation outside the tank and above the tank bottom (Parameter I) for the site conditions. See Figure 2.
- Follow that row to the right until reaching the column corresponding to the depth of soil cover above the tank top (Parameter II). See Figure 2.
- If the tank model is listed in that cell, then buoyancy control is required (proceed to Step 2). If the tank model is not listed in that cell, then no buoyancy control is required.
- IM-Series tanks shall not be installed where the uninterrupted saturated soil level outside the tank exceeds the height of the outlet pipe saddle.

**Table 1:
Infiltrator Tank Models' and Conditions Requiring Buoyancy Control**

Parameter I: Position of uninterrupted saturated soil conditions above tank bottom		Parameter II: Soil cover depth above tank top	
		A	B
		6 in (150 mm) to 12 in (300 mm)	Above 12 in (300 mm)
1	Above outlet pipe saddle* (greater than 43" [1,075 mm])	Do not install tank	Do not install tank
2	36" (900 mm) to 43" (1,075 mm) (to outlet pipe saddle)	All models	Not Required
3	30" (750 mm) to 36" (900 mm)	IM-1530	Not Required
4	Less than 30" (750 mm)	Not Required	Not Required

NOTES:

- Infiltrator tank models include: IM-540, IM-1060, and IM-1530.
- Minimum 6 inches (150 mm) soil cover backfill is required.
- IM-Series tanks shall not be installed where the uninterrupted saturated soil outside the tank exceeds the height of the outlet pipe saddle. See Figure 1. For Indiana installations, if the depth of uninterrupted saturated soil conditions cannot be determined from the site soil evaluation report or other site-related data and other information indicates the possible presence of a perched ground water table, no buoyancy controls are required.

Figure 1:

Limitations When Saturated Soil Conditions are Present Above Tank Bottom

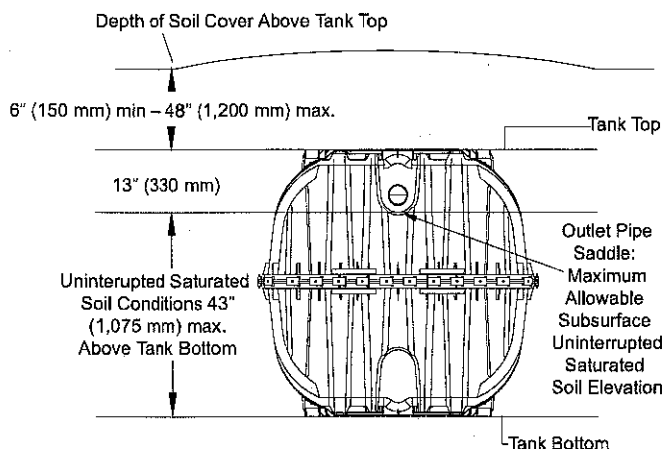
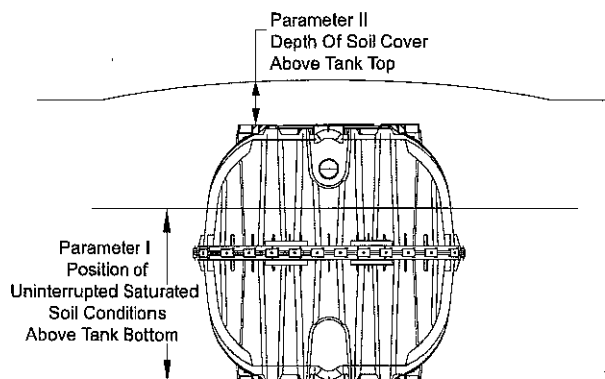

Figure 2:

Buoyancy Control Parameters for Table 1



Step 2 – Determine Buoyancy Control Method

Step 2 is used if the Step 1 analysis shows that buoyancy control is required for the tank model and installation conditions. The site-specific maximum height of uninterrupted saturated soil outside of the tank and above the tank bottom and the depth of soil cover above the tank top must be known to complete Step 2.

Table 2 Instructions

For the appropriate tank model, select the desired buoyancy control method under each method description column. Refer to Step 3 – Implementation and Compatible Devices and Products sections of this document for additional information on the buoyancy control methods shown in Table 2.

Table 2: Buoyancy Control Method Selection

Tank Model	Parameter I: Position of uninterrupted saturated soil conditions above tank bottom	Parameter II: Soil cover depth above tank top	Minimum supplemental downward force required (total, both tank sides)	Buoyancy Control Methods				
				Concrete-filled half pipe (min. length/side)	Concrete parking bumpers (min. length/side)	Concrete traffic barriers (min. length/side)	Helical anchors (min. no./side)	Concrete collar (min. width x min. height)
IM-540	36 in (900 mm) to outlet pipe saddle ²	6 in (150 mm) to 12 in (300 mm)	2,200 lbs (1,000 kg)	3.8 ft (1.2 m)	3.8 ft (1.2 m)	3.8 ft (1.2 m)	2	6 in (150 mm) x 9 in (225 mm)
IM-1060	36 in (900 mm) to outlet pipe saddle ²	6 in (150 mm) to 12 in (300 mm)	2,700 lbs (1,225 kg)	4.2 ft (1.3 m)	4.5 ft (1.4 m)	4.2 ft (1.3 m)	2	12 in (300 mm) x 9 in (225 mm)
IM-1530	30 in (750 mm) to outlet pipe saddle ²	6 in (150 mm) to 12 in (300 mm)	4,300 lbs (1,955 kg)	6.3 ft (2.0 m)	6.5 ft (2.0 m)	6.3 ft (2.0 m)	2	12 in (300 mm) x 9 in (225 mm)

NOTES:

1. See Supplemental Downward Force discussion below.
2. IM-Series outlet pipe saddle height is 43 inches (1,075 mm) above tank bottom (see Figure 1).

Supplemental Downward Force

The minimum supplemental downward force required is included in Table 2 to allow custom buoyancy control methods. These values include a factor of safety of 1.5 applied to the calculated downward force required to restrain the tank. Custom-designed buoyancy control methods shall conservatively consider saturated soil conditions from the bottom-of-tank elevation to ground surface. As long as buoyancy control is provided that supplies the minimum downward force listed in the table (for poured-concrete blocks or other methods designed by third parties), the tanks are calculated to be stable for the uninterrupted saturated soil level outside the tank and above the tank bottom and corresponding soil cover conditions. All Infiltrator strapping and fastening recommendations apply for custom-designed buoyancy control methods. Contact Infiltrator's Technical Services Department with any questions regarding supplemental downward force requirements.

Step 3 – Implementation

Effective buoyancy control of Infiltrator tanks requires careful preparation, thorough excavation, precise placement, secure strapping and proper backfilling, as described and illustrated below.

Excavation Requirements

It is recommended that the excavation width provide a minimum of 36 inches (900 mm) clearance beyond the tank on all sides when utilizing buoyancy control. This will allow sufficient space within the excavation to place anchoring equipment and fasten strapping. The excavation should provide a minimum 48-inch (1,200 mm) clearance beyond the tank when using Chance™ No-Wrench Screw Anchors to allow for room to properly install the screw anchors. The actual excavation size shall be determined by the installer. Refer to Infiltrator IM-Series Tank Installation Instructions for additional excavation procedures.

Concrete-filled Half Pipe Construction

Concrete-filled half pipe shall be supported with soil or other stabilizing means below the pipe haunches prior to concrete placement. The stabilization shall prevent the pipe from rolling during placement and curing of the concrete. Concrete shall be allowed to cure for a minimum of one day prior to tank backfilling.

Placement of Deadmen and Anchors

Concrete deadman anchors are to be installed at the bottom of the tank excavation, parallel to the long axis of the tank (see Figure 3).

Figure 3: Plan View

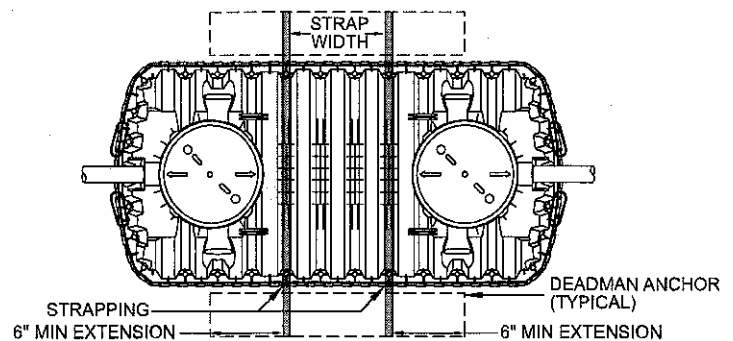

The deadmen should be placed close to, but not touching, the tank on both sides of the tank to allow the placement of backfill between the deadman anchor and tank sidewall (see Figure 4).

Figure 4: Section View

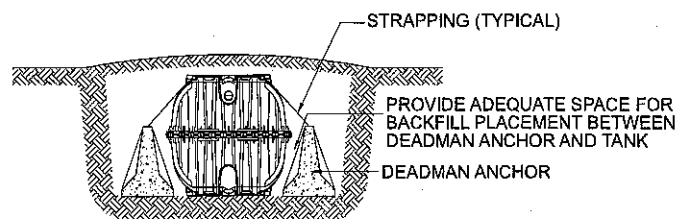

Step 3 – Implementation continued

Helical anchors should be installed so that the eye loop is level with the bottom of the tank excavation. They must be in line with the tank model strapping locations (see Figure 5) or lifting lugs, as appropriate. Anchors must also be installed at such a distance from and angle to the tank so that the strapping is within 5° of alignment with the anchor shaft per the anchor manufacturer's recommendations.

Figure 5: Strap Positioning

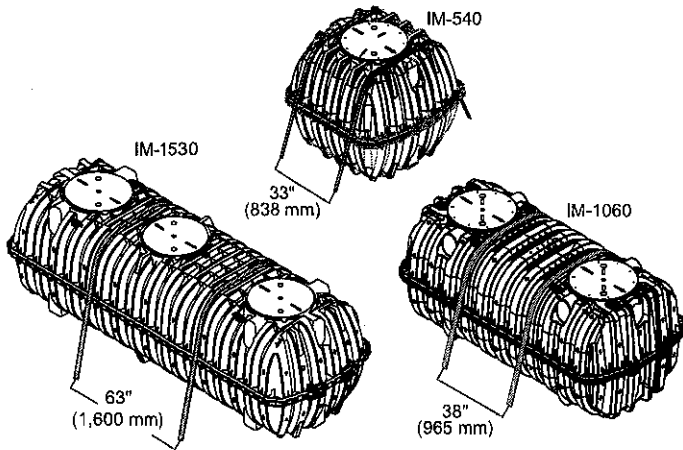

Concrete Collar

Backfill the tank to the mid-seam area. Concrete (minimum 3,000 psi at 28 days and minimum 6% air entrainment) shall be cast in contact with the exterior surface of the tank to allow interlock with sidewall ribs and the mid-height flange. The bottom of the concrete collar shall be cast at the top of the mid-seam flange.

SECTION VIEW

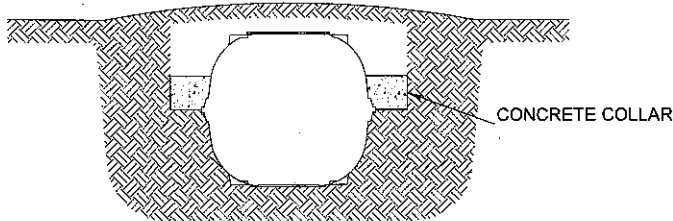

Strapping

Proper installation of straps over the tank is critical for tank stability under changing conditions both inside and outside the tank. Straps must be placed at the specified strapping locations for each model, as illustrated in Figure 5. Strapping locations are embossed on the exterior surface of the tank with the following text: "SHIPPING/ANTI-BUOYANCY STRAP HERE." The IM-Series tank strapping locations correspond to structurally reinforced areas of the tank body. Straps must never be placed over access openings, lids, or inlet/outlet piping. (Straps must be tightened with a ratchet or turnbuckle system to remove slack and slightly pre-load the system).

Strapping Notes:

1. The buoyancy control shall be centered across the straps (excludes helical anchors). The control shall extend a minimum of 6 inches (150 mm) beyond the maximum strap width (see Figures 3 and 5).
2. The minimum deadman length corresponds to the tank model-specific strap width plus 12 inches (300 mm).

Backfill and Cover

Place backfill between deadman anchor and tank sidewall to fully fill void and tank body corrugations. A minimum 6" layer (150 mm) of suitable cover material is required over all Infiltrator tank installations. Mound cover to direct surface water drainage away from the tank excavation footprint to prevent filling of the tank excavation with precipitation. Establish erosion-resistant vegetation within the tank installation footprint. Refer to Infiltrator IM-Series Tank Installation Instructions for complete backfilling and cover procedures.

Parts and Supplies

The parts and supplies necessary are to be purchased separately from the tank. All parts and supplies are either commercially available or available through Infiltrator's network of tank distributors. Some parts may require fabrication on site using common construction practices.

General Specifications

Compatible Devices and Products

Infiltrator tanks are compatible with the following products for buoyancy control:

- Tie-down straps: high-tensile-strength, 10,000 lb (4,500 kg) minimum capacity, nylon or polyester, with corrosion-resistant hardware.
- Concrete deadmen anchors: concrete-filled plastic half pipe, precast parking bumper, precast traffic barrier, or precast block.
- Helical anchors: Chance™ No-Wrench Screw Anchors with minimum 6-inch (150 mm) diameter, Class 7 or equal.
- Mid-Seam Concrete Collar: cast-in-place concrete (minimum 3,000 psi compressive strength at 28 days and minimum 6% air entrainment).

Tie-Down Straps

Straps are commercially available in varying lengths and with assorted hardware and tightening options.



Nylon or polyester strapping with minimum 8,000 lb (3,650 kg) capacity is required for buoyancy control use with Infiltrator tanks. Place straps over the tank at specified locations only (see Figure 5). (Tighten straps snugly with a ratchet or turnbuckle system to remove all slack and slightly pre-load the system). All connections, fittings, and hardware must be corrosion resistant or coated with epoxy or other corrosion-resistant materials to inhibit deterioration in the subsurface environment. Consider encapsulating such components in heat-shrink tubing or applying a corrosion-resistant coating prior to burial.

Concrete Deadmen Anchors

Recommended concrete deadmen anchors include filled plastic half pipe, precast parking bumpers and traffic barriers, and precast blocks. The weight of the deadmen anchors combined with the weight of soil above them provides buoyancy control when properly secured. Deadmen anchors are placed at the bottom of the tank excavation on opposite sides of the tank. The deadmen anchors are fastened to each other with tie-down straps placed over the tank at the locations specified for each tank model (see Figure 5).

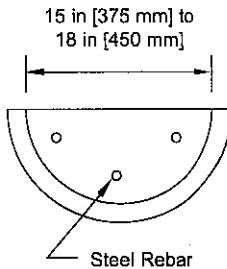

Concrete-filled Plastic Half Pipe

Use Schedule 40 PVC plastic pipe with a minimum inside diameter of 15 inches (375 mm) or HDPE corrugated pipe with a minimum inside diameter of 18 inches (450 mm) cut in half lengthwise. Fill with concrete having a minimum unit weight of 145 lbs/ft³ (2.32 metric tons/m³) reinforced with three equally spaced 40-grade, 1/2-inch (13 mm) diameter steel bars. Weight is 61 lbs/ft (91 kg/m) minimum.

Concrete Parking Bumper

Use commercially available steel-reinforced parking bumpers with typical dimensions of 12 inches wide by 6 inches high (300 mm x 150 mm). Weight is 58 lbs/foot (86 kg/m) minimum.

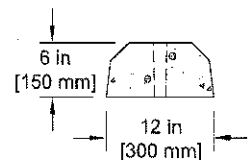

General Specifications continued

Concrete Traffic Barrier

Use commercially available steel-reinforced concrete traffic barrier or equivalent. Typical dimensions include a 24-inch-wide base tapering to a 6-inch-wide top, with a height of approximately 32 inches (600 mm x 150 mm x 800 mm). Weight is 390 lbs/foot (580 kg/m) minimum.

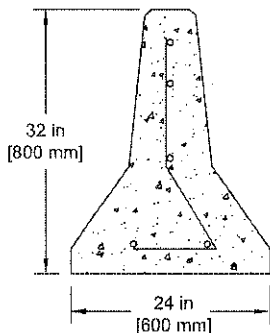

Precast Blocks

Concrete precasters can fabricate blocks of various dimensions and weights. Blocks are often an affordable option if they satisfy the minimum weight requirements for use as buoyancy control (see Table 2 and the Supplemental Force section of Step 2 for more information).

Helical Anchors

Chance™ No-Wrench Screw Anchors with a 6-inch (150 mm) diameter flight, Class 7, or equal. These anchors rely on the shear strength of the soil combined with the weight of the soil above the anchor flight to provide holding strength. Proper installation is to 4 feet (1.2 m) below the bottom of the tank excavation and to within 5° of alignment with the strap alignment. Determine the proper locations for anchor installation to ensure that tie-down straps will



Typical working torque:

- ¾" Rod 400 ft. lbs. (542 N-m)
- 1" Rod 1,000 ft. lbs. (1,356 N-m)
- 1¼" Rod 2,300 ft. lbs. (3,118 N-m)

be aligned properly for each tank model (see Step 3: Implementation), and follow the anchor manufacturer installation instructions.

Concrete Collar

A ballast may be constructed along the mid-height seam of the tank using cast-in-place concrete (minimum 3,000 psi compressive strength at 28 days and minimum 6% air entrainment). Concrete shall be cast in contact with the exterior surface of the tank to allow interlock with sidewall ribs and the mid-height flange. Reinforcing steel is not required, but may be added if desired.

General Information

- Prior to ground disturbance, check for subsurface obstructions and utilities in conformance with applicable regulatory requirements.
- Excavation safety provisions shall conform to applicable government regulations.
- Follow manufacturer instructions for all products and devices used for Infiltrator tank buoyancy control.
- Buoyancy control methods described herein do not account for unanticipated conditions such as surface flooding, temporary inundation or other natural occurrences, unintended removal of cover fill over tank, etc.
- Buoyancy control methods described herein are recommendations only; consult a professional engineer for customized designs, if desired.

Infiltrator Water Technologies, LLC ("Infiltrator")

INFILTRATOR® SEPTIC TANK LIMITED WARRANTY FIVE (5) YEAR MATERIALS AND WORKMANSHIP LIMITED WARRANTY

- (a) This limited warranty is extended to the end user of an Infiltrator Tank. A Tank manufactured by Infiltrator, when installed and operated in accordance with Infiltrator's installation instructions and local regulation by a person or company that is properly qualified to install the Infiltrator tank in accordance with applicable state and/or local requirements, is warranted to you: (i) against defective materials and workmanship for five (5) years after installation. Infiltrator will, at its option, (i) repair the defective product or (ii) replace the defective materials. Infiltrator's liability specifically excludes the cost of removal and/or installation of the Tank.
- (b) In order to exercise its warranty rights, you must notify Infiltrator in writing at its corporate headquarters in Old Saybrook, Connecticut within fifteen (15) days of the alleged defect.
- (c) YOUR EXCLUSIVE REMEDY WITH RESPECT TO ANY AND ALL LOSSES OR DAMAGES RESULTING FROM ANY CAUSE WHATSOEVER SHALL BE SPECIFIED IN SUBPARAGRAPH (a) ABOVE. INFILTRATOR SHALL IN NO EVENT BE LIABLE FOR ANY CONSEQUENTIAL OR INCIDENTAL DAMAGES OF ANY KIND, HOWEVER OCCASIONED, WHETHER BY NEGLIGENCE OR OTHERWISE. SOME STATES DO NOT ALLOW THE EXCLUSION OR LIMITATION OF INCIDENTAL OR CONSEQUENTIAL DAMAGES, SO THIS LIMITATION OR EXCLUSION MAY NOT APPLY TO YOU. THIS WARRANTY GIVES YOU SPECIFIC LEGAL RIGHTS AND YOU MAY ALSO HAVE OTHER RIGHTS WHICH VARY FROM STATE TO STATE.
- (d) THIS LIMITED WARRANTY IS THE EXCLUSIVE WARRANTY GIVEN BY INFILTRATOR AND SUPERSEDES ANY PRIOR, CONTRARY, ADDITIONAL, OR SUBSEQUENT REPRESENTATIONS, WHETHER ORAL OR WRITTEN. INFILTRATOR DISCLAIMS AND EXCLUDES TO THE GREATEST EXTENT ALLOWED BY LAW ALL OTHER WARRANTIES, WHETHER EXPRESS OR IMPLIED, OR STATUTORY, INCLUDING ANY WARRANTY OF MERCHANTABILITY, FINESSE FOR A PARTICULAR PURPOSE AND ANY IMPLIED WARRANTIES OTHERWISE ARISING FROM COURSE OF DEALING, COURSE OF PERFORMANCE, OR USAGE OF TRADE. NO PERSON (INCLUDING ANY EMPLOYEE, AGENT, DEALER, OR REPRESENTATIVE) IS AUTHORIZED TO MAKE ANY REPRESENTATION OR WARRANTY CONCERNING THIS PRODUCT, EXCEPT TO REFER YOU TO THIS LIMITED WARRANTY. EXCEPT AS EXPRESSLY SET FORTH HEREIN, THIS WARRANTY IS NOT A WARRANTY OF FUTURE PERFORMANCE, BUT ONLY A WARRANTY TO REPAIR OR REPLACE.
- (e) YOU MAY ASSIGN THIS LIMITED WARRANTY TO A SUBSEQUENT PURCHASER OF YOUR HOME.
- (f) NO REPRESENTATIVE OF INFILTRATOR HAS THE AUTHORITY TO CHANGE THIS LIMITED WARRANTY IN ANY MANNER WHATSOEVER, OR TO EXTEND THIS LIMITED WARRANTY.
- (g) NO WARRANTY OF ANY KIND IS MADE WITH REGARD TO ANY PRODUCT, COMPONENTS, DEVICES, MEDIA OR TREATMENT UNITS WHICH ARE MANUFACTURED BY OTHERS AND ARE INSTALLED IN AN INFILTRATOR TANK. USE OF THESE PRODUCTS ARE AT YOUR OWN RISK.
- (h) THE INFILTRATOR TANK IS DESIGNED TO BE BURIED UNDERGROUND. NO WARRANTY OF ANY KIND IS MADE IF YOUR TANK IS NOT BURIED UNDERGROUND AS SPECIFIED IN THE PRODUCT'S INSTALLATION INSTRUCTIONS.

CONDITIONS AND EXCLUSIONS

There are certain conditions or applications over which Infiltrator has no control. Defects or problems as a result of such conditions or applications are not the responsibility of Infiltrator and are NOT covered under this warranty. They include failure to install the Tank in accordance with instructions or applicable regulatory requirements or guidance, altering the Tank contrary to the installation instructions and disposing of chemicals or other materials contrary to normal tank usage.

The above represents the Standard Limited Warranty offered by Infiltrator. A limited number of regulatory jurisdictions have different warranty requirements. Any purchaser of a Tank should contact Infiltrator's corporate headquarters in Old Saybrook, Connecticut, prior to such purchase to obtain a copy of the applicable warranty, and should carefully read that warranty prior to the purchase of a Tank.



INFILTRATOR
water technologies

4 Business Park Road
P.O. Box 768
Old Saybrook, CT 06475
860-577-7000 • Fax 860-577-7001
1-800-221-4436
www.infiltratorwater.com
info@infiltratorwater.com

U.S. Patents: 4,759,661; 5,017,041; 5,156,486; 5,336,017; 5,401,116; 5,401,459; 5,511,903; 5,716,163; 5,588,778; 5,839,844 Canadian Patents: 1,329,959; 2,004,564 Other patents pending. Infiltrator, Equalizer, Quick4, and SideWinder are registered trademarks of Infiltrator Water Technologies. Infiltrator is a registered trademark in France. Infiltrator Water Technologies is a registered trademark in Mexico. Contour, MicroLeaching, PolyTuff, ChamberSpacer, MultiPort, PosiLock, QuickCut, QuickPlay, SnapLock and StraightLock are trademarks of Infiltrator Water Technologies. PolyLok is a trademark of PolyLok, Inc. TUF-TITE is a registered trademark of TUF-TITE, INC. Ultra-Rib is a trademark of IPEX Inc.