

# hydro·action<sup>®</sup>

assembled and distributed by Wastewater Solutions, Inc.<sup>®</sup>

## *Owner's Instruction Manual*

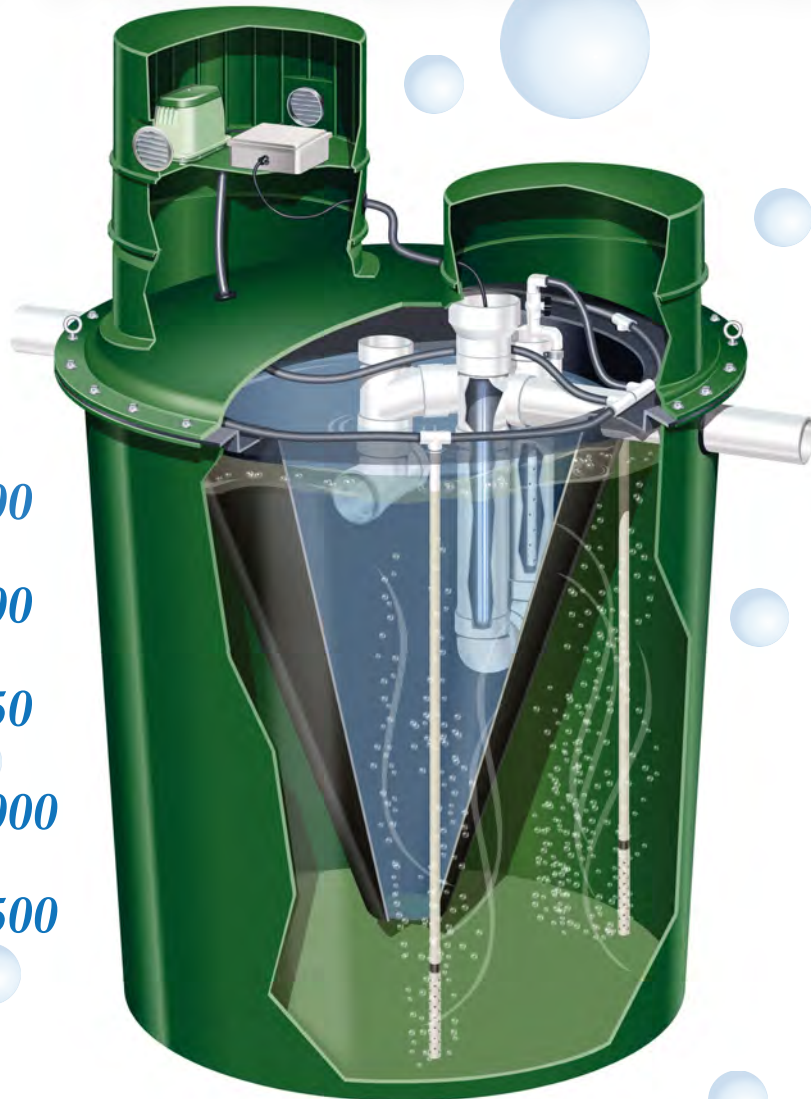

- Model AP-500*
- Model AP-600*
- Model AP-750*
- Model AP-1000*
- Model AP-1500*

*Class 1 NSF/ANSI Standard 40 AP Series  
Wastewater Treatment Plant*

*20650 Alliance-Sebring Rd  
Phone: 330-823-7536 Fax: 330-823-7435*



# Hydro-Action AP Series Wastewater Treatment Plant

The AP Series Aerobic Treatment Units (ATUs) are now available through **Hydro-Action®**. Please read this introduction before reviewing this manual.

Earth's environment has purified water through natural processes since the beginning of time. Only recently, beginning in the Twentieth Century, has man developed a system to accelerate the processes that Mother Nature uses. **Hydro-Action®** AP Series ATUs are just such systems.

In 1916, the City of Houston, Texas, was the first to use the activated sludge wastewater treatment process as an accepted, full-scale system process to purify domestic wastewater. Since that time, the United States and many other nations have utilized this process and variations to properly treat sewage. Federal Law 92-500 supports our nation's commitment to provide secondary treatment for all domestic wastewater.

This commitment is presently being extended to on-site sewage treatment facilities. **Hydro-Action®** has been a visible part of this effort since 1989. We have manufactured numerous products to provide individuals with a means of proper, effective, efficient, and affordable on-site wastewater treatment. Our professional commitment to market needs and customer service have enabled us to reach our goal of providing effective products that assure a safe, reusable effluent. We are helping Mother Nature protect our environment and our most valuable natural resource: water.

Our continuing mission is to develop and manufacture individual on-site wastewater treatment facilities that meet society's needs in the field. This manual is a part of that dedication to customer service.

**Hydro-Action®** AP Series Aerobic Treatment Units are among the most advanced on-site products available today. They are state-of-the-art extended aeration, activated sludge wastewater treatment facilities. The improvements in these units make them not

only extremely efficient operational units but also the most easily maintainable system in the industry.

By following the instructions in this manual, you will be providing yourself with the best on-site wastewater treatment and service. We invite you to share in our pride of the AP Series Treatment Units.

This manual includes information on the AP-500, AP-600, AP-750, AP-1000G & AP-1500G wastewater treatment plants. These units may be installed with either a platform mounted OPS® (operations/control center) or a Remotely Located OPS®. Installation needs vary, so your on-site wastewater system may contain some of the following auxiliary plant components along with the treatment plant:

- Pretreatment tank
- Pump/holding tank
- Alarm systems
- Equipment for chosen effluent disposal method (drip irrigation, spray irrigation, gravel-filled drain field, pressure dosing, etc.)
- Chlorinator / UV Disinfection Unit

The certified **Hydro-Action®** dealer or installer of your **Hydro-Action®** AP Series wastewater treatment plant is responsible for completing and submitting to us the Installation Warranty Information to properly activate your **Hydro-Action®** Product Warranty.

We are eager to assist you with any questions or problems. Please contact **Hydro-Action®** at 800.370.3749 to request assistance from our Customer Service or Engineering Departments.

## Process Description

The **Hydro-Action**<sup>®</sup> AP Series individual wastewater treatment plant is a self-contained, extended aeration, aerobic treatment facility utilizing the activated sludge process. The plant consists of a cylindrically shaped aeration tank with an offset service access, a unique cone shaped clarification compartment, and an outlet tee-assembly. Two fine-bubble air diffuser assemblies with ceramic stone diffusers and **Hydro-Action**<sup>®</sup> s' efficient air pump are combined to provide effective, efficient, and economical aeration.

Domestic wastewater enters the aeration compartment and is mixed thoroughly with the already present mixed liquor suspended solids (MLSS) activated sludge. The injection of air through the porous ceramic air diffusers placed near the bottom of the aeration chamber is responsible for this complete mixing. The fine bubble air diffusers and the vortex area between diffuser assemblies produce a generous quantity of dissolved oxygen and ample mixing that maintain a desirable aerobic environment even under extreme conditions.

Hydraulic displacement causes the mixed liquor to enter the clarification compartment and move upward toward the outlet tee-assembly. Due to the calm conditions in the clarifier, suspended solids settle to the bottom where they are remixed with the MLSS for additional biological treatment. The remaining clarified effluent leaves the plant via the outlet tee-assembly and discharge line.

The AP Series ATUs are operated by the OPS<sup>®</sup>. The OPS<sup>®</sup> integrates the electrical controls, visible and audible alarms and air pump in a protective polyethylene enclosure. The OPS<sup>®</sup> can be either platform mounted on the plant or remotely located. These features plus; the offset access, flexible air hose, and anchored diffuser assemblies make the plant extremely reliable and easy to service. An optional visible and audible alarm may be added to remotely locate to an area of your choice.

The technology used in the **Hydro-Action**<sup>®</sup> plant allows it to produce excellent effluent quality, which thereby meets all ANS\NSF

International Standard 40 class I and the Environmental Protection Agency's requirements of a secondary treatment process. NSF requires that a Class I plant shall be shown to meet EPA secondary treatment guidelines for CBOD5, TSS, and pH. The **Hydro-Action**<sup>®</sup> AP Series ATUs satisfy all these requirements.

## Operating Instructions

Your **Hydro-Action**<sup>®</sup> ATU has been designed and built to provide efficient, dependable and reliable service. However, as with any individual wastewater treatment plant, routine periodic service is required. When proper preventive maintenance is performed, the ATU will operate at designed performance levels giving years of satisfactory treatment of domestic wastewater.

The local dealer from whom you purchased your **Hydro-Action**<sup>®</sup> plant will perform all routine inspections for the first two (2) years from the original date of installation. At the time of inspection the plant will be checked for proper operation. If a problem exists, service will be performed at no charge to the owner if the required maintenance is warranty related. At the end of the two (2) year initial service period, your local dealer will make available a continuing service policy. This extended service is available for a nominal fee.

The **Hydro-Action**<sup>®</sup> ATU's electrical controls are located within the OPS<sup>®</sup> of the plant. The OPS<sup>®</sup> may be either remotely located or platform mounted. The OPS<sup>®</sup> enclosure is equipped with an alarm beacon and an audible alarm. Also on the enclosure will be the name, address and telephone number of your local servicing dealer. It is this local service provider you should contact regarding any problems with your **Hydro-Action**<sup>®</sup> ATU. An optional remote alarm with audible and visible alarms may also be present. If the alarm beacon or audible alarm sounds simply switch the OPS<sup>®</sup> switch to silent and call the service provider mentioned above. After a power failure, if an alarm remains on for more than 30 minutes you should call the local dealer immediately.

The **Hydro-Action**<sup>®</sup> plant will handle all domestic wastewater from your home. By the

term wastewater we are referring to rapidly biodegradable material. To keep maintenance at a minimum level and to prevent the plant from malfunctioning, the following guidelines must be followed:

Since aerobic bacteria are responsible for treating the wastewater, inorganic or non-rapidly biodegradable materials should not be put into the plant. Examples of improper items are: included in the “Homeowner Care Precautions” section of this manual.

Other than for the mechanical and structural working of the plant itself, **Hydro-Action®** is not responsible for the in-field operation of a plant. The proper operation of this or any other individual wastewater plant depends upon proper organic and hydraulic loading of the plant. We cannot control the loading and thereby control the amount of harmful substances that may be discharged into the plant. Only the users of a plant can control what enters the unit. Therefore, we provide this comprehensive user manual to outline just what substances to keep out of the plant.

## **Maintenance Schedule**

Maintenance is to be performed by an authorized **Hydro-Action®** service provider only! Normal maintenance of your **Hydro-Action®** plant every six (6) months will include:

- a. Service check of aeration system and air diffusers.
- b. Service check of air pump.
- c. Removal of scum from clarifier.
- d. Inspect and test plant alarms.
- e. Sludge check and pump excess sludge from plant every two (2) to six (6) years.

**Note 1:** Replacement parts can be obtained from your installing or servicing representative. Visit [www.hydro-action.com](http://www.hydro-action.com) for a list of certified representatives.

**Note 2:** Pumping the plant is usually necessary every two (2) to six (6) years; however, there is no set time because loadings vary from household to household. Access to the plant is accomplished through

the 24-inch access opening, which is at surface grade. When a **Hydro-Action®** plant is being pumped, a qualified service technician should oversee the job. Care should be taken not to damage internal components and the plant should be washed and cleaned while it is being pumped. All waste from the plant must be disposed of in compliance with all federal, state and local laws.

## **Compliance With Law**

All permits and approvals from the local regulatory body should first be obtained before the **Hydro-Action®** plant is installed. All state and federal laws should be obeyed in areas that do not have local control over environmental activities. It is important to remember that each state has independent regulations and guidelines for the installation of this treatment plant and any auxiliary equipment that may accompany the plant. You are responsible for installing this plant and associated ancillary items in accordance with all regulations and guidelines as they are issued in your respective state. If such items as pretreatment tanks, storage or equalization tanks, chlorination facilities, pump tanks, Ultra-violet, etc. are required by law, then it is the intent of this company to comply to the letter of the law.

**Hydro-Action®**, through its years of experience, recognizes the advantages of every component of the wastewater treatment system. Because of this experience we can recommend to you those parts of a system that are beneficial to the overall system and those that are also compliant with the laws in your state. Please call our Customer Service Department for assistance or inquiries at 800.370.3749.

## **Plant Start-Up**

Upon ATU start-up, no additional procedures are required. The system has been filled with water, and the air pump, electrical controls, and alarms are functional per installation checkout. Turning on the electrical power is all that is required for you to start using your facilities.

Even after a short or extended vacation, your system will begin to operate as designed once use is initiated and maintained. In just a few days the system should return to normal operation and you should see a clear, clean discharge having very little or no odor. If not, call your service provider for assistance and a plant inspection.

## **Safety**

Safety is an important issue in our business since we deal with one of the more potentially health hazardous materials known: raw sewage. Domestic wastewater carries in it members of a specialized group of life known as microorganisms. Such microorganisms are bacteria, viruses, algae, actinomycetes, protozoa, fungi, rotifers, crustaceans, and other members of both the plant and animal worlds. The function of a wastewater treatment plant is to treat the water to a degree that the effluent is relatively free of pathogenic bacteria and nuisance microorganisms. Until the wastewater entering the plant has had sufficient time for treatment and disinfection, it may contain any number of the harmful organisms that cause disease.

As raw wastewater may and usually does contain some level of unsafe microorganisms, proper respect and care must be given to safety. Whenever you come into contact with raw sewage, do not fear the contact, but do take proper precautions to avoid potential danger. Follow these simple safety precautions whenever exposed to wastewater:

- Wear disposable rubber gloves when handling wastewater contaminated items or chlorine tablets.
- Always wash with soap and water after handling any contaminated item. The use of good bactericide soap is strongly recommended.
- Always dispose of scum, rags, trash, debris, or soiled material in a proper waste container.
- If a wastewater spill or leak occurs in a yard, flush area with plenty of clean

water and disinfect. If a spill or leak occurs in the house, clean with a dilute solution of bleach.

- Treated effluent from a **Hydro-Action**<sup>®</sup> or other treatment unit may still contain harmful microorganisms. Careful attention must be used when dealing with any form of wastewater or effluent.
- If an illness or disease is suspected to have come from exposure to sewage, get proper medical attention immediately. When proper treatment is given the remedy and cure will be rapid and less of a problem. There are some serious diseases that could be transmitted by contact with raw sewage -take the proper precautions and be safe!

## **Homeowner Care Precautions**

All Aerobic Wastewater Treatment Systems are suspended growth floating bio-mass systems designed to treat common household sewage only.

In plain language, this means that the systems contain and depend on an aerobic (oxygen-requiring) bacterial colony which, when well cared for, digests and treats household sewage just as aerobic bacteria clean groundwater in nature. This is why aerobic systems have an air pump and air distribution piping – for supplying the aerobic bacteria with oxygen. Bacteria, however, can't eat just anything and everything. For a listing of things to avoid feeding to an aerobic bacterial system, see below.

Normal maintenance is required on all aerobic treatment units, as they are activated sludge sewage treatment systems just like large municipal water treatment plants. Our factory-trained **Hydro-Action**<sup>®</sup> installers or service technicians regularly service our installations, checking to be sure that these systems are in proper working order.

Aerobic systems are not designed for disposal of solid waste or chemicals. If homeowners stay within the guidelines listed below, their systems should function properly as sewage treatment systems and should not require unscheduled maintenance or frequent expensive pump-outs.

## **What NOT to put in an aerobic treatment system:**

- Non-biodegradable items such as cigarette butts, match sticks, disposable diapers, feminine hygiene products, condoms, hair, coffee grounds, rags, paper towels, and bandages, flushable kitty litter, wipes etc. These are solid-waste items and should be disposed of in regular trash service.
- Greases, fats or oils. This includes cooking oils and meat or meat grease.
- Pesticides, herbicides, photographic chemicals or other toxins.
- Paints, thinners or household chemicals, including many cleaning compounds, and mop-bucket water.
- Water softener unit backwash.
- Citrus products, oranges, lemons, grapefruit.
- Home-brewery or winemaking wastes.
- Strong medicines, particularly antibiotics.
- Antibacterial soaps and antibacterial laundry detergents should be avoided. These are the current marketing rage, but overuse will only breed resistant strains of bacteria in the home, and kill the aerobic action in the treatment system.
- Strong disinfectants or bleaches, particularly products containing chlorine or ammonia.
- Commercial septic tank additives; they do more harm than good.
- Kitchen garbage grinders (disposals) should be used sparingly, if at all. Dispose of food waste in a solid waste bin or compost heap. Food waste represents additional loading on the aerobic plant, possibly causing organic overloading and more frequent pump-outs of the system.

## **Volumetric Overload of an Aerobic System:**

Our system is rated for a maximum volume throughput per day, ie. 500 gallons per day (GPD) for an AP-500, 600 GPD for an AP-600, etc., and only household wastewater (sinks, tubs, washing machines, toilets, etc.) should be allowed into the unit. 'Volumetric overloading' is simply a term used to describe putting more than the rated amount of wastewater through the system during a 24 hour period.

To avoid volumetric overloading of our system, which can result in incomplete treatment conditions, observe the following:

- Avoid multiple wash loads in one day; spread out your laundry during the week.
- Watch for leaking/flowing faucets or toilets and repair immediately.
- Use water flow reducing devices whenever possible.
- Be aware of any excessive water use of any kind.

## **Home Cleaning Products Guidelines:**

- Recommended laundry detergents are: Powdered, low-sudsing, low-phosphate, non-antibacterial and bio-degradable.
- Recommended household cleaning products are: Non-chlorine, non-ammonia, non-antibacterial, non-toxic and bio-degradable.

PART/PRINT NO.  
---

PART DESCRIPTION  
AP500

DATE  
8/22/12

NOTE:  
1<sup>FT</sup> SOIL DEPTH CREDIT

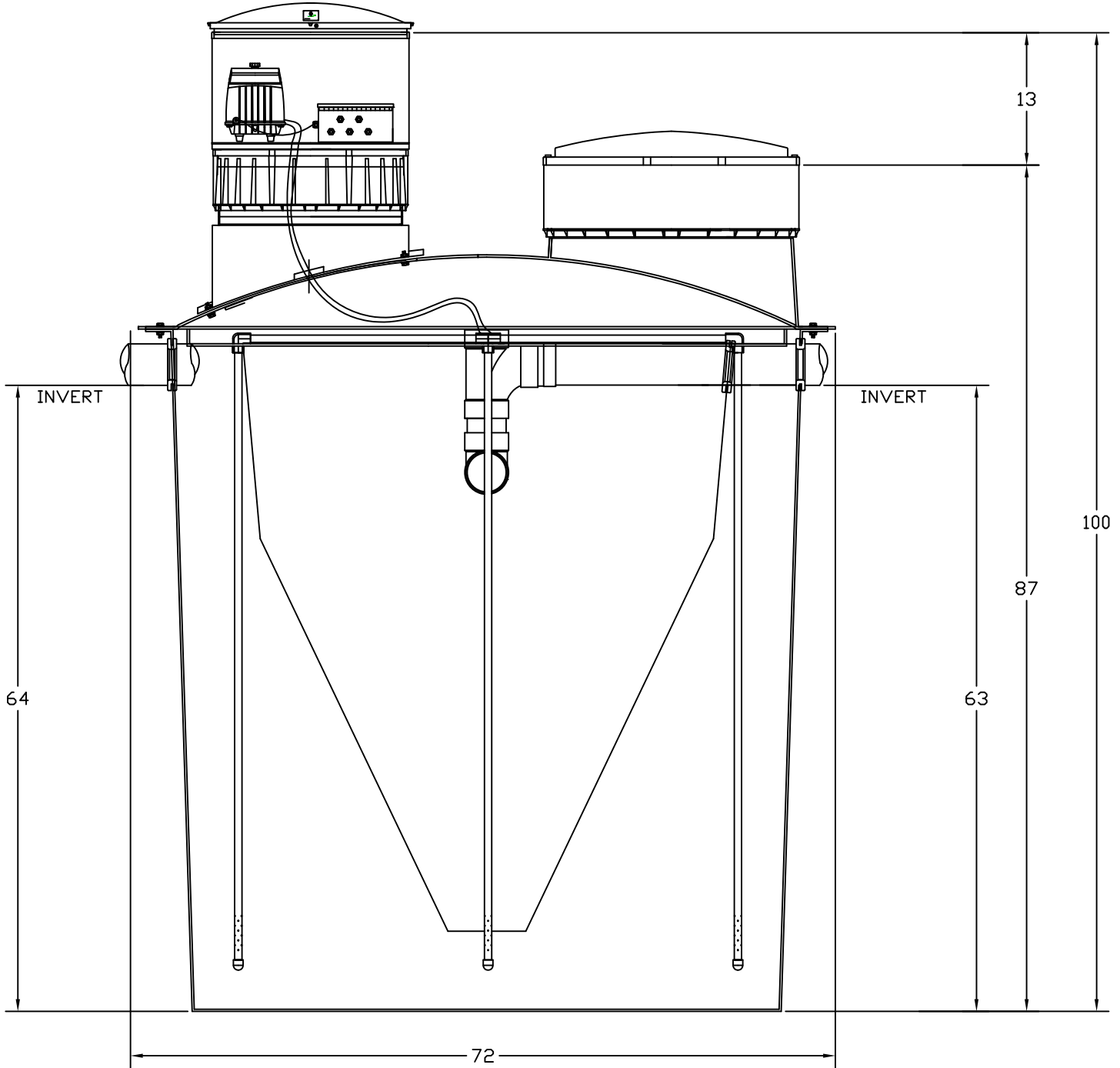

DRAWN  
A.DAVIS

APPROVED BY

SIGNATURE

# Hydro-Action<sup>®</sup> Limited Warranty

AK/HA Manufacturing, LLC d/b/a Hydro-Action Industries ("Hydro-Action Industries") warrants to you, the purchaser, that each Hydro-Action Industries aerobic wastewater treatment plant ("Plant"), and its component parts, are free from defects in material and workmanship under the terms and conditions set forth in this Limited Warranty. No employee, dealer, agent or other person is authorized to make any warranty or representation with respect to the Plant, other than as is expressly contained in this Limited Warranty.

## COVERAGE PERIOD

This Limited Warranty is effective for an initial period of 2 years beginning on the date of purchase as evidenced by purchaser's proof of purchase. An additional 3 year, prorated, warranty period will run upon the expiration of the first 2 years if the Plant is maintained by an authorized distributor through a continuous maintenance program.

## HOW TO MAKE A WARRANTY CLAIM

If you believe that the Plant or a component part of the Plant is defective in material or workmanship, you must return it to an authorized Hydro-Action Industries dealer. The dealer will return the Plant or component part to Hydro-Action Industries at 2055 Pidco Drive, Plymouth, Indiana 46563. You must also provide to Hydro-Action Industries a written description of the nature of the defect. No claim will be processed unless you specify the nature of the defect. If a claim is being made during years 3, 4, or 5 of this Warranty, you must also provide proof that the Plant has been maintained by an authorized distributor through a continuous maintenance program. All claims must be made within 30 days of the discovery of the defect.

Upon receipt of the written description of the defect and Plant or component part, Hydro-Action Industries will examine the Plant or component part. If, in Hydro-Action Industries' reasonable judgment, the Plant or component part shows evidence of defects in material or workmanship, Hydro-Action Industries will replace or exchange the component part as set forth in the following schedule. Please note that Hydro-Action Industries reserves the right to revise, change or modify the construction and design of any Plant, or any component part of such Plant, without incurring any obligations to make changes or modifications in previously sold equipment. Hydro-Action Industries reserves the right to furnish a replacement component part, which, in its judgment, is equivalent to the part replaced.

For claims received within 30 days of the expiration of Year 1 and Year 2 of this Warranty, Hydro-Action Industries will replace or exchange the component part at no cost to you.

If the Plant has been maintained by an authorized distributor through a continuous maintenance program:

For component parts of the Plant manufactured by someone other than A.K. Industries, Inc., Hydro-Action Industries will sell such parts to you under the following schedule: (1) claims received within 30 days of the expiration of Year 3 of this Warranty, Hydro-Action Industries will replace or exchange the component part for a cost to you of 25% of the manufacturer's list price of such part and Hydro-Action will pay 75% of the cost; (2) for claims received within 30 days of the expiration of Year 4, Hydro-Action will replace such part for a cost to you of 50% of the manufacturer's list price and Hydro-Action will pay 50% of the cost; and (3) for claims received within 30 days of the expiration of Year 5, Hydro-Action will replace such part for a cost to you of 75% of the manufacturer's list price and Hydro-Action will pay 25% of the cost.

For claims received during years 3, 4, and 5 of this Limited Warranty or within 30 days of the expiration of Year 5, Hydro-Action Industries will replace or exchange any component part manufactured by AK Industries, Inc. at no cost to you.

## WHAT IS NOT COVERED

This Limited Warranty does not cover any defects resulting from damage resulting from transit, accidents, misuse, alterations, or acts of God. This Limited Warranty does not apply to Plants or components parts that have not been fully paid for or for which acceptable payments terms have not been arranged. No warranty is made as to the field performance of any systems. This Limited Warranty does not include any costs of labor. This Limited Warranty does not apply to consumables, including, but not limited to, stones, filters, etc. This Limited Warranty does not cover Plants that have been: (1) flooded by external means; (2) disassembled by unauthorized persons; (3) improperly installed; or (4) subjected to external damage or damage due to altered or improper wiring or overload protection.

## CONDITIONS AND LEGAL REMEDIES

This Limited Warranty is governed by the laws of the State of Indiana. The sole remedy under this Limited Warranty is the replacement or exchange of parts. **Hydro-Action Industries SHALL NOT BE LIABLE FOR ANY INCIDENTAL OR CONSEQUENTIAL DAMAGES. THIS LIMITED WARRANTY IS MADE IN LIEU OF ANY OTHER EXPRESS OF IMPLIED WARRANTIES.** Hydro-Action Industries **DISCLAIMS ANY IMPLIED WARRANTIES ARISING IN CONNECTION WITH THE SALE OF THE PLANT, INCLUDING ANY IMPLIED WARRANTIES OF MERCHANTABILITY OR FITNESS FOR A PARTICULAR PURPOSE.**

Some states do not allow the disclaimer of warranties or the exclusion or limitation of incidental or consequential damages and so the above limitations may not apply to you.



# **Hydro-Action<sup>®</sup>**

## **Complaint Procedure & Form**

### **Procedure**

Homeowners must make every effort to direct complaints with the appropriate service agent. For example, if the complaint is related to the initial install the Certified Installer should be contacted. Likewise, if the condition is a service issue the Certified Service Technician should be notified. The appropriate chain should be utilized to best accommodate the customer. The order of contact should be Certified Service Technician, Certified Installer, Certified Dealer, Certified Distributor, and lastly the Manufacturer. Hydro-Action being the manufacturer is glad to be of assistance in aiding the contact of these different agents.

If all efforts to verbally resolve a situation have been made and the customer is unsatisfied then a written complaint may be necessary. Below consists of a complaint form that may be sent to the manufacturer to file a formal grievance. The manufacturer will then begin an internal inquiry to investigate the situation on a case-by-case basis. A Hydro-Action Sales Associate will be assigned to the matter and begin to resolve the situation. Hydro-Action will make every effort in customer satisfaction, and assist the homeowner/customer to investigate the situation. A final finding will be reported to the customer either verbally or in writing. Hydro-Action will discuss the matter with the customer to make a fair effort to resolve the situation.

### **Form**

Please fill out this form and send to **Hydro-Action<sup>®</sup>** at P.O. Box 640 Plymouth, IN. 46563. A copy should also be sent to the Local Health Department, and the State Health Department or Wastewater Governing Body.

**Date:** \_\_\_\_\_

#### **Person Filing Complaint:**

**Distributor/Dealer/Installer/Service Tech/Home-owner (circle one)**

**Name:** \_\_\_\_\_

**Address:** \_\_\_\_\_

**Phone:** \_\_\_\_\_

#### **Complaint About:**

**Distributor/Dealer/Installer/Service Tech/Home-owner (circle one)**

**Name:** \_\_\_\_\_

**Address:** \_\_\_\_\_

**Phone:** \_\_\_\_\_

**Please describe the problem in detail: (use additional pages if necessary)**

---

---

---

---

---

---

---

---

---

---

# **Hydro-Action<sup>®</sup>**

## **Initial Service Policy**

Our company, \_\_\_\_\_ will provide a two-year initial service policy, which will provide for inspection and service of your **Hydro-Action<sup>®</sup>** plant. The policy will include the following:

- Four inspection/service calls (at least one every six (6) months) over the two (2) year period including inspection, adjustment and servicing of the mechanical electrical and other applicable component parts to ensure proper function. This includes inspecting OPS<sup>®</sup>, air pump, air filter, diffuser operation, and cleaning and replacing or repairing any component not found to be functioning correctly.
- An effluent quality inspection consisting of a visual check for color, turbidity, scum overflow and examination for odors.

If any improper operation is observed that cannot be corrected at that time you shall be notified immediately in writing of the conditions and the estimated date of correction.

At the conclusion of the initial service policy, our company will make available, for purchase on an annual basis, a continuing service policy to cover labor for normal inspection, maintenance and repair.

Owner/user operation instructions must be strictly followed or warranties are subject to invalidation.

Pumping of sludge build-up from the plant, if necessary, is not included in these services.

Owner:

Date: \_\_\_\_\_

Date: \_\_\_\_\_

Service Dealer:



**AK/HA Manufacturing LLC.**

**2055 Pidco Dr. / P.O. Box 640  
Plymouth, IN. 46563**

**Toll Free: 800.370.3749  
Phone:(574) 936-2542  
Fax: (574) 936-2298**

**[www.hydro-action.com](http://www.hydro-action.com)**

rev. 07/10